



























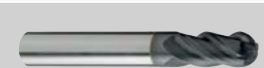







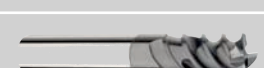







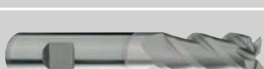

FRÄSEN VHM MILLING VHM (SOLID CARBIDE)

ARTIKEL-BESCHREIBUNG ARTICLE-DESCRIPTION		ARTIKEL-NR. ARTICLE-NO.	SEITE PAGE	STAHL	INOX	NE-METALLE	GUSS	TITAN	HRC	GRAPHIT	
HPC-SUPERSTAR HPC-SUPERSTAR											
		Blue Cut E.7675W.1	9	✓	✓	✓		✓			
		Blue Cut E.7675H.1	9	✓		✓	✓	✓			
		Blue Cut E.7676W.1	9	✓	✓	✓		✓			
		Blue Cut E.7676H.1	9	✓		✓	✓	✓			
		Blue Cut SET.7676.1	9	✓		✓	✓	✓			
		Blue Cut E.7698W.1	10	✓	✓	✓		✓			
		Blue Cut E.7698H.1	10	✓		✓	✓	✓			
		Blue Cut E.7602.1	10	✓		✓	✓	✓			
		Blue Cut E.7609.1	11	✓				✓			
		Blue Cut E.7612.1	12	✓				✓			
		Blue Cut E.7614.1	12	✓				✓			✓
		Blue Cut E.7615.1	13	✓			✓	✓			
		Blue Cut E.7716.1	13	✓				✓	✓		
		Blue Cut E.7728.1	14	✓					✓		
		Blue Cut E.7785.1	14	✓	✓	✓	✓				
		Blue Cut E.7661.1	14	✓	✓	✓	✓	✓			
INOX INOX											
		E.7604.0	15		✓	✓					
		E.7611.0	16		✓	✓					
		Blue Cut E.7693.1	17		✓	✓		✓			
		 Blue Cut E.7673.1	17		✓	✓		✓			
		 Blue Cut E.7674.1	18		✓	✓		✓			

Gewindbohrer	1
Bohren HSSE	2
Bohren VHM	3
Reiben HSSE	4
Reiben VHM	5
Frässtifte VHM	6
Fräsen VHM	7
WP-Werkzeuge	8
Fräsen HSSE	9
Sägen	10
Lehren	11
Nachschleifen	12
Sonstiges	13

Die angegebenen Einsatzgebiete sind Richtlinien. Die genauen Einsatzdaten finden Sie im jeweiligen Artikel!

The indicated operational areas are estimated guide lines. The exact dates of use please find at the specified articles!



































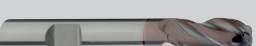

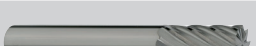

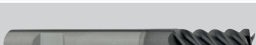

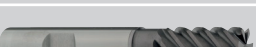

















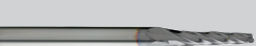

FRÄSEN VHM MILLING VHM (SOLID CARBIDE)

ARTIKEL-BESCHREIBUNG ARTICLE-DESCRIPTION	ARTIKEL-NR. ARTICLE-NO.	SEITE PAGE	STAHL	INOX	NE-METALLE	GUSS	TITAN	HRC	GRAPHIT	
	E.7601.0	19	✓		✓					
	E.7601.1	19	✓	✓	✓	✓				
	E.7603.0	20	✓	✓	✓	✓				
	E.7603.1	20	✓	✓	✓	✓		✓		
	E.7606.0	21	✓	✓	✓					
	E.7613.1	22	✓	✓	✓	✓				
	E.7666.1	22	✓							
	E.7618.1	23	✓							
	E.7653.1	23	✓							
	E.7647.1	24	✓							
	E.7660.1	24	✓							
	E.7641.1	25	✓		✓	✓		✓		
	E.7622.1	26	✓		✓	✓				
	E.7668.1	26	✓	✓	✓					
	E.7626.0	27	✓			✓				
	E.7623.1	28	✓			✓				
	E.7624.1	28	✓			✓				
	E.7625.1	29	✓			✓				
	E.7628.0	29	✓	✓	✓	✓				
	E.7631.1	30	✓	✓	✓	✓				
	E.7632.1	30	✓	✓	✓	✓				
	E.7634.1	31	✓	✓	✓	✓		✓		

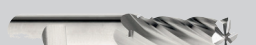
Die angegebenen Einsatzgebiete sind Richtlinien. Die genauen Einsatzdaten finden Sie im jeweiligen Artikel!

The indicated operational areas are estimated guide lines. The exact dates of use please find at the specified articles!

FRÄSEN VHM MILLING VHM (SOLID CARBIDE)











	ARTIKEL-BESCHREIBUNG ARTICLE-DESCRIPTION			ARTIKEL-NR. ARTICLE-NO.	SEITE PAGE	STAHL	INOX	NE-METALLE	GUSS	TITAN	HRC	GRAPHIT	
			Blue Cut	E.7662.1	31	✓			✓				
				E.7648.0	32	✓	✓	✓	✓				
			Blue Cut	E.7649.1	33	✓		✓	✓				
			Blue Cut	E.7650.1	33	✓		✓	✓				
			Blue Cut	E.7651.1	34	✓	✓	✓					
			Blue Cut	E.7652.1	34	✓	✓	✓					
			Blue Cut	E.7723.1	35	✓	✓	✓		✓	✓		
			Blue Cut	E.7670.1	35	✓		✓	✓		✓		
			Blue Cut	E.7657.1	36	✓			✓		✓		
				E.7680.0	37	✓	✓	✓	✓				
			Blue Cut	E.7701.1	37	✓		✓					
			Blue Cut	E.7681.1	38	✓		✓			✓		
				E.7688.0	38	✓	✓	✓	✓				
UNISPEZIAL UNISPECIAL													
				E.6607.0	39	✓	✓	✓					
				E.6608.0	40	✓	✓	✓					
			Blue Cut	E.6609.1	40	✓	✓	✓					
				E.7627.0	41	✓							
				E.7635.0	41	✓							
				E.7704.0	42	✓		✓	✓		✓		
				E.7705.0	42	✓		✓	✓		✓		
				E.7671.0	43	✓		✓	✓				
				E.7629.0	44	✓		✓	✓		✓		

Gewindbohrer	1
Bohren HSSE	2
Bohren VHM	3
Reiben HSSE	4
Reiben VHM	5
Frässtifte VHM	6
Fräsen VHM	7
WP-Werkzeuge	8
Fräsen HSSE	9
Sägen	10
Lehren	11
Nachschleifen	12
Sonstiges	13

Die angegebenen Einsatzgebiete sind Richtlinien. Die genauen Einsatzdaten finden Sie im jeweiligen Artikel!

The indicated operational areas are estimated guide lines. The exact dates of use please find at the specified articles!

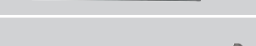















FRÄSEN VHM MILLING VHM (SOLID CARBIDE)

	ARTIKEL-BESCHREIBUNG ARTICLE-DESCRIPTION	ARTIKEL-NR. ARTICLE-NO.	SEITE PAGE	STAHL	INOX	NE-METALLE	GUSS	TITAN	HRC	GRAPHIT	
	 	E.7630.0	44	✓		✓	✓		✓		
		E.7658.0	45	✓	✓	✓	✓				
		E.7659.0	45	✓	✓	✓	✓				
	 	E.7683.1	46	✓	✓	✓	✓				

SCHRUPPFRÄSER ROUGHING END MILLS

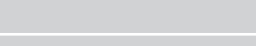
	  	E.7677.1	47	✓	✓	✓	✓				
	  	E.7663.1	47	✓	✓	✓	✓				
	  	E.7664.1	48	✓	✓	✓	✓				
	  	E.7665.1	48	✓	✓	✓	✓				✓
	  	E.7672.1	49		✓			✓			
	  	E.7633.1	49	✓			✓		✓		
	  	E.7678.1	50	✓	✓	✓		✓			
	  	SET.7678.1	50	✓	✓	✓		✓			
	  	E.7724.1	50	✓	✓	✓		✓			
	  	E.7718.1	51	✓	✓	✓	✓				
	  	E.7669.1	51						✓		
	  	E.7679.1	52	✓	✓	✓		✓			

ALUMINIUM ALUMINIUM

	 	E.6602.0	53			✓					
	 	E.6611.0	54			✓					
	 	E.7684.0	54			✓					
	  	E.7694.0	55			✓					
	  	E.7695.1	55			✓					

Die angegebenen Einsatzgebiete sind Richtlinien. Die genauen Einsatzdaten finden Sie im jeweiligen Artikel!

The indicated operational areas are estimated guide lines. The exact dates of use please find at the specified articles!

FRÄSEN VHM MILLING VHM (SOLID CARBIDE)

ARTIKEL-BESCHREIBUNG ARTICLE-DESCRIPTION	ARTIKEL-NR. ARTICLE-NO.	SEITE PAGE	STAHL	INOX	NE-METALLE	GUSS	TITAN	HRC	GRAPHIT	
$Z=2$ $\lambda=30^\circ$ POLIERT polished	E.7690.0	56			✓					
$Z=2$ $\lambda=30^\circ$ SPEZIAL BESCHICHTUNG COATING	E.7691.1	56			✓					
$Z=2$	E.7607.0	57			✓	✓				
$Z=2$	E.7685.0	58			✓	✓				
$Z=2$ $\lambda=55^\circ$	E.7608.0	58			✓					
$Z=2$ $\lambda=25^\circ$	E.7617.0	59			✓					
$Z=2$ $\lambda=40^\circ$ SPEZIAL BESCHICHTUNG COATING	E.7621.1	59			✓					
$Z=3$ $\lambda=45^\circ$	E.7636.0	60			✓					
$Z=3$ $\lambda=45^\circ$	E.7637.0	60			✓					
$Z=4$ $\lambda=45^\circ$ POLIERT polished	E.7715.0	61			✓				✓	
MEHR SCHNEIDER $\lambda=40^\circ$	E.7646.0	61			✓					
MEHR SCHNEIDER $\lambda=20^\circ$	E.7727.0	62			✓					
MEHR SCHNEIDER	E.7755.0	62			✓					
MEHR SCHNEIDER $\lambda=30^\circ$	E.7756.0	63			✓					
MEHR SCHNEIDER $\lambda=25^\circ$	E.7757.0	63			✓					
MEHR SCHNEIDER $\lambda=20^\circ$	E.7758.0	63			✓					
MEHR SCHNEIDER $\lambda=30^\circ$	E.7759.0	64			✓					
MEHR SCHNEIDER $\lambda=20^\circ$	E.7760.0	64			✓					
MEHR SCHNEIDER $\lambda=30^\circ$	E.7761.0	65			✓					
MEHR SCHNEIDER	E.7762.0	65			✓					
MEHR SCHNEIDER	E.7763.0	66			✓					
MEHR SCHNEIDER	E.7764.0	66			✓					

Gewindbohrer	1
Bohren HSSE	2
Bohren VHM	3
Reiben HSSE	4
Reiben VHM	5
Frässtifte VHM	6
Fräsen VHM	7
WP-Werkzeuge	8
Fräsen HSSE	9
Sägen	10
Lehren	11
Nachschleifen	12
Sonstiges	13

Die angegebenen Einsatzgebiete sind Richtlinien. Die genauen Einsatzdaten finden Sie im jeweiligen Artikel!

The indicated operational areas are estimated guide lines. The exact dates of use please find at the specified articles!





























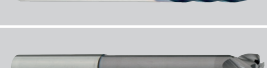















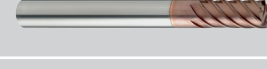







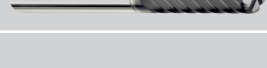

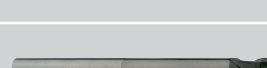

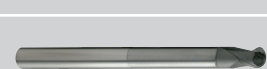

FRÄSEN VHM MILLING VHM (SOLID CARBIDE)

ARTIKEL-BESCHREIBUNG ARTICLE-DESCRIPTION	ARTIKEL-NR. ARTICLE-NO.	SEITE PAGE	STAHL	INOX	NE-METALLE	GUSS	TITAN	HRC	GRAPHIT	
FORMENBAU MOULDS										
	Blue Cut	E.7689.1	67	✓					✓	
	Blue Cut	E.7642.1	68	✓					✓	
	Blue Cut	E.7719.1	69	✓					✓	
	Blue Cut	E.7720.1	69	✓					✓	
	Blue Cut	E.7640.1	70-71	✓					✓	
	Blue Cut	E.7731.1	72	✓					✓	
	Blue Cut	E.7732.1	72	✓					✓	
	Blue Cut	E.7639.1	73	✓					✓	
	Blue Cut	E.7610.1	73	✓					✓	
	Blue Cut	E.7730.1	74	✓					✓	
	Blue Cut	E.7605.1	75-76	✓					✓	
	Blue Cut	E.7729.1	77	✓					✓	
	Blue Cut	E.7734.1	77	✓					✓	
	Blue Cut	E.7735.1	78	✓					✓	
	Blue Cut	E.7737.1	78	✓					✓	
	SPEZIAL BESCHICHTUNG COATING	E.7643.1	79	✓					✓	
	SPEZIAL BESCHICHTUNG COATING	E.7644.1	80	✓					✓	
	Blue Cut	E.7645.1	80	✓					✓	
	Blue Cut	E.7638.1	81	✓					✓	
	Blue Cut	E.7738.1	81	✓					✓	
	Blue Cut	E.7739.1	82	✓					✓	
	SPEZIAL BESCHICHTUNG COATING	E.7697.1	82	✓					✓	

Die angegebenen Einsatzgebiete sind Richtlinien. Die genauen Einsatzdaten finden Sie im jeweiligen Artikel!

The indicated operational areas are estimated guide lines. The exact dates of use please find at the specified articles!

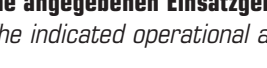
FRÄSEN VHM MILLING VHM (SOLID CARBIDE)

















	ARTIKEL-BESCHREIBUNG ARTICLE-DESCRIPTION			ARTIKEL-NR. ARTICLE-NO.	SEITE PAGE	STAHL	INOX	NE-METALLE	GUSS	TITAN	HRC	GRAPHIT	
			Blue Cut	E.7740.1	83	✓					✓		
			Blue Cut	E.7741.1	83	✓					✓		
			Blue Cut	E.7742.1	84	✓					✓		
			SPEZIAL BESCHICHTUNG COATING	E.7699.1	84	✓					✓		
			Blue Cut	E.7654.1	85-86	✓					✓		
			Blue Cut	E.7733.1	87	✓					✓		
			Blue Cut	E.7743.1	88	✓					✓		
			Blue Cut	E.7655.1	89	✓					✓		
			SPEZIAL BESCHICHTUNG COATING	E.7744.1	90	✓					✓		
			Blue Cut	E.7745.1	90	✓					✓		
			Blue Cut	E.7746.1	91	✓					✓		
			Blue Cut	E.7682.1	92	✓					✓		
			Blue Cut	E.7619.1	93	✓					✓		
			SPEZIAL BESCHICHTUNG COATING	E.7686.1	93	✓					✓		
			Blue Cut	E.7747.1	94	✓					✓		
			Blue Cut	E.7748.1	95	✓					✓		
			Blue Cut	E.7749.1	95	✓					✓		
GRAPHIT GRAPHITE													
			DIAMANT BESCHICHTUNG COATING	E.7696.1	96-97							✓	
			DIAMANT BESCHICHTUNG COATING	E.7692.1	98-99							✓	
			DIAMANT BESCHICHTUNG COATING	E.7765.1	99							✓	
			DIAMANT BESCHICHTUNG COATING	E.7766.1	100							✓	
			DIAMANT BESCHICHTUNG COATING	E.7782.1	101							✓	

Gewindbohrer	1
Bohren HSSE	2
Bohren VHM	3
Reiben HSSE	4
Reiben VHM	5
Frässtifte VHM	6
Fräsen VHM	7
WP-Werkzeuge	8
Fräsen HSSE	9
Sägen	10
Lehren	11
Nachschleifen	12
Sonstiges	13



Die angegebenen Einsatzgebiete sind Richtlinien. Die genauen Einsatzdaten finden Sie im jeweiligen Artikel!

The indicated operational areas are estimated guide lines. The exact dates of use please find at the specified articles!

FRÄSEN VHM MILLING VHM (SOLID CARBIDE)

	ARTIKEL-BESCHREIBUNG ARTICLE-DESCRIPTION	ARTIKEL-NR. ARTICLE-NO.	SEITE PAGE	STAHL	INOX	NE- METALLE	GUSS	TITAN	HRC	GRAPHIT	
	  $\lambda=30^\circ$ DIAMANT BESCHICHTUNG COATING	E.7712.1	101							✓	
	 $\lambda=30^\circ$ DIAMANT BESCHICHTUNG COATING	E.7767.1	102							✓	
	 $\lambda=30^\circ$ DIAMANT BESCHICHTUNG COATING	E.7778.1	102							✓	
	 $\lambda=30^\circ$ DIAMANT BESCHICHTUNG COATING	E.7779.1	102							✓	
	 $\lambda=30^\circ$ DIAMANT BESCHICHTUNG COATING	E.7780.1	103							✓	
	 $\lambda=25^\circ$ DIAMANT BESCHICHTUNG COATING	E.7781.1	103							✓	
	  $\lambda=30^\circ$ DIAMANT BESCHICHTUNG COATING	E.7714.1	103							✓	

RUNDSTÄBE RODS

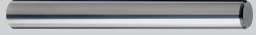
		E.7783.0	104								
		E.7784.0	105								
		E.7752.0	106								

Die angegebenen Einsatzgebiete sind Richtlinien. Die genauen Einsatzdaten finden Sie im jeweiligen Artikel!
 The indicated operational areas are estimated guide lines. The exact dates of use please find at the specified articles!

VHM-HPC-Superstar-Fräser (ungleiche Teilung) kurz

E.7675W.1

Universal

VHM WERKS-NORM Blue Cut

DIN 6535 HB KURZ SHORT INOX

Z=4 N/mm² ≤ 700 TITAN

E.7675H.1

Universal

VHM WERKS-NORM Blue Cut

DIN 6535 HB KURZ SHORT STAHL

Z=4 N/mm² ≤ 1400 <45 HRC

- Solid carbide HPC Superstar end mills (unequal pitch) short
- Frezy Superstar z węgla spiekanego czterostrzowe krótkie do obróbki wysokowydajnej (HPC)
- Frese in MD superstar, divisione irregolare, serie corta
- Fresas de metal duro "Superstar HPC" (división irregular), serie corta

Artikel-Nr. Article-No.				E.7675W.1 € Stück piece	E.7675H.1 € Stück piece
d1	l2	l1	d2 h6		
3,00	6	54	6,0		
4,00	8	54	6,0		
5,00	9	54	6,0		
6,00	10	54	6,0		
7,00	12	58	8,0		
8,00	12	58	8,0		
9,00	14	66	10,0		
10,00	14	66	10,0		
11,00	16	73	12,0		
12,00	16	73	12,0		
14,00	18	75	14,0		
16,00	22	82	16,0		
18,00	24	84	18,0		
20,00	26	92	20,0		
25,00	32	92	25,0		

VHM-HPC-Superstar-Fräser (ungleiche Teilung) lang

E.7676W.1

Universal

VHM WERKS-NORM Blue Cut

DIN 6535 HB LANG LONG INOX

Z=4 N/mm² ≤ 700 TITAN

E.7676H.1

Universal

VHM WERKS-NORM Blue Cut

DIN 6535 HB LANG LONG STAHL

Z=4 N/mm² ≤ 1400 <45 HRC

SET.7676.1



- Solid carbide HPC Superstar end mills (unequal pitch) long
- Zestaw frezów Superstar z węgla spiekanego czterostrzowych długich do obróbki wysokowydajnej (HPC)
- Frese in MD superstar, divisione irregolare, serie lunga
- Fresas de metal duro "Superstar HPC" (división irregular), serie larga

Artikel-Nr. Article-No.				E.7676W.1 € Stück piece	E.7676H.1 € Stück piece
d1	l2	l1	d2 h6		
3,00	8	57	6,0		
4,00	11	57	6,0		
5,00	13	57	6,0		
6,00	13	57	6,0		
7,00	19	63	8,0		
8,00	19	63	8,0		
9,00	22	72	10,0		
10,00	22	72	10,0		
11,00	26	83	12,0		
12,00	26	83	12,0		
14,00	26	83	14,0		
16,00	32	92	16,0		
18,00	32	92	18,0		
20,00	38	104	20,0		
25,00	38	104	25,0		

VHM-HPC-Superstar-Fräser (ungleiche T.) abgesetzt

E.7698W.1

Universal

VHM WERKS (COMPANY) NORM Blue Cut

DIN 6535 HB LANG LONG INOX

Z=4 N/mm² ≤ 700 TITAN

E.7698H.1

Universal

VHM WERKS (COMPANY) NORM Blue Cut

DIN 6535 HB LANG LONG STAHL

Z=4 N/mm² ≤ 1400 <45 HRC

- Solid carbide HPC Superstar end mills (unequal pitch) reduced
- Frezy Superstar z węgla spiekane go czterostrzowe zredukowane do obróbki wysokowydajnej (HPC)
- Frese in MD superstar, divisione irregolare, ribassate
- Fresas de metal duro "Superstar HPC" (división irregular), serie rebajada

Artikel-Nr. Article-No.					E.7698W.1	E.7698H.1
d1	l2	l3	l1	d2 h6	€ Stück piece	€ Stück piece
4,00	8	18	57	6,0		
5,00	13	21	57	6,0		
6,00	13	21	57	6,0		
7,00	19	27	63	8,0		
8,00	19	27	63	8,0		
9,00	22	32	72	10,0		
10,00	22	32	72	10,0		
11,00	26	38	83	12,0		
12,00	26	38	83	12,0		
13,00	26	42	83	14,0		
14,00	26	42	83	14,0		
16,00	32	44	92	16,0		
18,00	32	50	100	18,0		
20,00	38	54	104	20,0		

VHM-HPC-Superstar-Fräser (ungleiche T.) extra lang

E.7602.1

Universal

VHM WERKS (COMPANY) NORM Blue Cut

DIN 6535 HA XLANG XLONG STAHL

Z=4 N/mm² ≤ 1400 <45 HRC

- Solid carbide HPC Superstar end mills (unequal pitch) extra long
- Frezy Superstar z węgla spiekane go czterostrzowe bardzo długie do obróbki wysokowydajnej (HPC)
- Frese in MD superstar, divisione irregolare serie extra lunga
- Fresas de metal duro "Superstar HPC" (división irregular), serie extra larga

Artikel-Nr. Article-No.					E.7602.1
d1	l2	l1	d2 h6	€ Stück piece	
5,00	21	63	6,0		
6,00	22	63	6,0		
8,00	28	80	8,0		
10,00	33	100	10,0		
12,00	42	100	12,0		
14,00	48	100	14,0		
16,00	53	150	16,0		
20,00	68	150	20,0		

- 1 Gewindebohrer
- 2 Bohren HSSE
- 3 Bohren VHM
- 4 Reiben HSSE
- 5 Reiben VHM
- 6 Frässtifte VHM
- 7 Superstar
- 8 WP-Werkzeuge
- 9 Fräsen HSSE
- 10 Sägen
- 11 Lehren
- 12 Nachschleifen
- 13 Sonstiges

VHM-HPC-Superstar-Fräser (ungleiche T.) mit Eckenradius

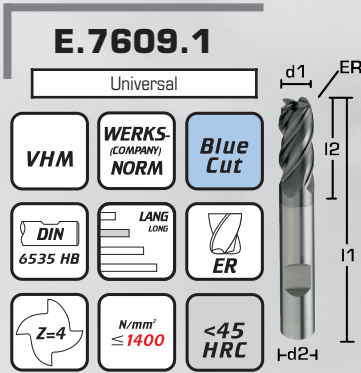

 Solid carbide HPC Superstar end mills (unequal pitch) with corner radius

 Frezy Superstar z węglika spiekanego czterostrzowe długie do obróbki wysokowydajnej (HPC) z promieniem

 Frese in MD superstar, divisione irregolare, con raggio d'angolo

 Fresas de metal duro "Superstar HPC" (división irregular) con radio lateral





Artikel-Nr. Article-No.					E.7609.1 € Stück piece
d1	ER + - 0,02	l2	l1	d2 h6	
4,00	0,25	11	57	6,0	
4,00	0,50	11	57	6,0	
4,00	1,00	11	57	6,0	
5,00	0,50	13	57	6,0	
5,00	1,00	13	57	6,0	
5,00	1,50	13	57	6,0	
6,00	0,50	13	57	6,0	
6,00	1,00	13	57	6,0	
6,00	1,50	13	57	6,0	
6,00	2,00	13	57	6,0	
8,00	0,50	19	63	8,0	
8,00	1,00	19	63	8,0	
8,00	1,50	19	63	8,0	
8,00	2,00	19	63	8,0	
10,00	0,50	22	72	10,0	
10,00	1,00	22	72	10,0	
10,00	1,50	22	72	10,0	
10,00	2,00	22	72	10,0	
12,00	0,50	26	83	12,0	
12,00	1,00	26	83	12,0	
12,00	1,50	26	83	12,0	
12,00	2,00	26	83	12,0	
14,00	1,00	26	83	14,0	
14,00	2,00	26	83	14,0	
16,00	1,00	32	92	16,0	
16,00	1,50	32	92	16,0	
16,00	2,00	32	92	16,0	
16,00	2,50	32	92	16,0	
18,00	1,50	32	92	18,0	
18,00	2,50	32	92	18,0	
20,00	1,00	38	104	20,0	
20,00	1,50	38	104	20,0	
20,00	2,00	38	104	20,0	
20,00	2,50	38	104	20,0	
20,00	3,00	38	104	20,0	
20,00	4,00	38	104	20,0	
20,00	5,00	38	104	20,0	

VHM-HPC-Superstar-Radius-Fräser (ungleiche T.)

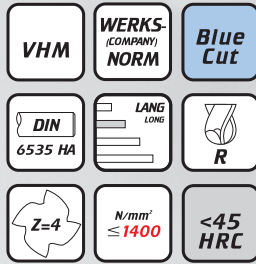
E.7612.1

Universal



-  Solid carbide HPC Superstar ball nose end mills (unequal pitch)
-  Frezy Superstar z węgla spiekane go czterostrzowe z czołem kulistym do obróbki wysokowydajnej (HPC)
-  Frese in MD superstar, divisione irregolare, raggriate
-  Fresas de radio de metal duro "Superstar HPC" (división irregular)

Artikel-Nr. Article-No.





d1	R	l2	l1	d2 h6	E.7612.1 € Stück piece
3,00	1,5	8	57	6,0	
4,00	2,0	13	57	6,0	
5,00	2,5	13	57	6,0	
6,00	3,0	13	57	6,0	
8,00	4,0	16	63	8,0	
10,00	5,0	22	72	10,0	
12,00	6,0	26	83	12,0	
14,00	7,0	26	83	14,0	
16,00	8,0	32	92	16,0	
20,00	10,0	38	104	20,0	

VHM-HPC-Superstar-Fräser (ungleiche T.) mit IK

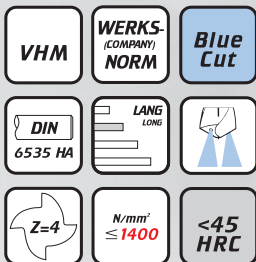
E.7614.1

Universal



-  Solid carbide HPC Superstar end mills (unequal pitch) with internal coolant
-  Frezy Superstar z węgla spiekane go czterostrzowe z chłodzeniem wew. do obróbki wysokowydajnej (HPC)
-  Frese in MD superstar, divisione irregolare, con refrigerazione interna
-  Fresas de metal duro "Superstar HPC" (división irregular) con refrigeración interior





Artikel-Nr. Article-No.

d1	l2	l1	d2 h6	E.7614.1 € Stück piece
6,00	13	57	6,0	
8,00	16	63	8,0	
10,00	22	72	10,0	
12,00	26	83	12,0	
16,00	32	92	16,0	
20,00	38	104	20,0	

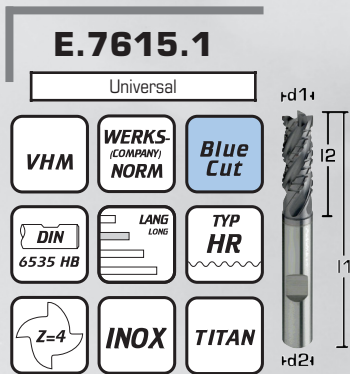
- Gewindebohrer 1
- Bohren HSSE 2
- Bohren VHM 3
- Reiben HSSE 4
- Reiben VHM 5
- Frässtifte VHM 6
- Superstar 7
- WP-Werkzeuge 8
- Fräsen HSSE 9
- Sägen 10
- Lehren 11
- Nachschleifen 12
- Sonstiges 13

VHM-HPC-Superstar-Schruppfräser (ungleiche Teilung)





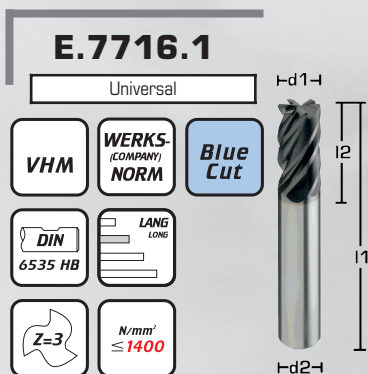

-  Solid carbide HPC Superstar roughing end mills (unequal pitch)
-  Frezy Superstar z węgla spiekane czterostrzowe do obróbki zgrubnej wysokowydajnej (HPC)
-  Frese in MD superstar a rompitrucolo, divisione irregolare, a sgrassare
-  Fresas de desbaste de metal duro "Superstar HPC" (división irregular)

Artikel-Nr. Article-No.				E.7615.1 € Stück piece
d1	l2	l1	d2 h6	
4,00	11	57	6,0	
5,00	13	57	6,0	
6,00	13	57	6,0	
8,00	16	63	8,0	
10,00	22	72	10,0	
12,00	26	83	12,0	
14,00	26	83	14,0	
16,00	32	92	16,0	
20,00	38	104	20,0	

VHM-HPC-Superstar-Schlichtfräser (ungleiche Teilung)



-  Solid carbide HPC Superstar finishing end mills (unequal pitch)
-  Frezy Superstar z węgla spiekane trzystrozdow do obróbki wykańczającej wysokowydajnej (HPC)
-  Frese in MD superstar rompitrucolo, divisione irregolare, a finire
-  Fresas de acabado de metal duro "Superstar HPC" (división irregular)

1 Vorschneide und 1 Fertigschneide
1 taper cutting edge and 1 finishing cutting edge

Artikel-Nr. Article-No.					E.7716.1 € Stück piece
d1	l2	l1	d2 h6	Zähne flutes	
6,00	13	57	6,0	3 / 6	
8,00	19	63	8,0	3 / 6	
10,00	22	72	10,0	3 / 6	
12,00	26	83	12,0	3 / 6	
16,00	32	92	16,0	3 / 6	
20,00	38	104	20,0	3 / 6	
25,00	42	110	25,0	3 / 6	

VHM-HPC-HSC-Fräser

E.7728.1

Universal

VHM WERKS (COMPANY) NORM Blue Cut

DIN 6535 HA ≤65 HRC HSC TOOL

Z=4 UNIVERSAL TOOL

E.7785.1

Universal

VHM WERKS (COMPANY) NORM Blue Cut

DIN 6535 HA UNIVERSAL TOOL

Z=4

- Solid carbide HPC HSC end mills
- Frezy czterostrzowe z węgla spiekane go do obróbki wysokowydajnej (HPC) szybkościowej (HSC)
- Frese in MD HPC HSC per alte prestazioni
- Fresas de metal duro HPC para alta velocidad

Artikel-Nr. Article-No.				E.7728.1 € Stück piece	E.7785.1 € Stück piece
d1	l2	l1	d2 h6		
4,00	11	57	6,0		
5,00	13	57	6,0		
6,00	13	57	6,0		
8,00	19	63	8,0		
10,00	22	72	10,0		
12,00	26	83	12,0		
14,00	26	83	14,0		
16,00	32	92	16,0		
18,00	32	92	18,0		
20,00	38	104	20,0		

VHM-HPC-Superstarfräser-Superfinish (ungleiche Teilung)

E.7661.1

Universal

VHM WERKS (COMPANY) NORM Blue Cut

DIN 6535 HA

Z=6 UNIVERSAL TOOL

- Solid carbide HPC Superstar end mills (unequal pitch) superfinish
- Frezy Superstar z węgla spiekane go sześciostrzowe do obróbki superfinishowej wysokowydajnej (HPC)
- Frese in MD superstar, divisione irregolare per superfinitura
- Fresas de acabado superfino de metal duro "Superstar HPC" (división irregular)

Artikel-Nr. Article-No.				E.7661.1 € Stück piece
d1	l2	l1	d2 h6	
8,00	19	63	8,0	
10,00	22	72	10,0	
12,00	26	83	12,0	
16,00	32	92	16,0	
20,00	38	104	20,0	
25,00	42	110	25,0	





- Gewindebohrer 1
- Bohren HSSE 2
- Bohren VHM 3
- Reiben HSSE 4
- Reiben VHM 5
- Frässtifte VHM 6
- Superstar 7
- WP-Werkzeuge 8
- Fräsen HSSE 9
- Sägen 10
- Lehren 11
- Nachschleifen 12
- Sonstiges 13

VHM-Inox-Mikroschaftfräser

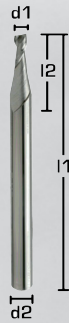
E.7604.0

2.1 2.2 4.1 4.2 4.4 4.7



-  Solid carbide Inox micro end mills
-  Frezy miniaturowe z węgla spiekanego dwuostrzowe do stali nierdzewnej
-  Microfresse in MD inox
-  Microfresas de metal duro para inoxidable

Artikel-Nr. Article-No.				E.7604.0 € Stück piece
d1 +0,005	l2	l1	d2 h4	
0,05	0,10	39	3,0	
0,06	0,12	39	3,0	
0,07	0,14	39	3,0	
0,08	0,16	39	3,0	
0,09	0,18	39	3,0	
0,10	0,20	39	3,0	
0,15	0,30	39	3,0	
0,20	0,40	39	3,0	
0,25	0,50	39	3,0	
0,30	0,60	39	3,0	
0,35	0,70	39	3,0	
0,40	0,80	39	3,0	
0,45	0,90	39	3,0	
0,50	1,00	39	3,0	
0,60	1,20	39	3,0	
0,70	1,40	39	3,0	
0,80	1,60	39	3,0	
0,90	1,80	39	3,0	
1,00	2,50	50	4,0	
1,10	2,50	50	4,0	
1,20	3,00	50	4,0	
1,30	3,00	50	4,0	
1,40	3,00	50	4,0	
1,50	4,00	50	4,0	
1,60	4,00	50	4,0	
1,70	4,00	50	4,0	
1,80	5,00	50	4,0	
1,90	5,00	50	4,0	
2,00	6,00	50	4,0	
2,10	6,00	50	4,0	
2,20	6,00	50	4,0	
2,30	7,00	50	4,0	
2,40	7,00	50	4,0	
2,50	7,00	50	4,0	
2,60	7,00	50	4,0	
2,70	7,00	50	4,0	
2,80	8,00	50	4,0	
2,90	8,00	50	4,0	
3,00	12,00	50	4,0	
3,50	12,00	50	4,0	
4,00	14,00	50	4,0	
4,50	14,00	50	5,0	
5,00	16,00	50	5,0	
6,00	19,00	64	6,0	

VHM-Inox-Mikroradiusfräser

E.7611.0

2.1 2.2 4.1 4.2 4.4 4.7

VHM WERKS-NORM NE-METALLE

INOX $\lambda = 30^\circ$ R

Z=2 DIN 6535 HA



- Solid carbide Inox micro ball nose end mills
- Frezy miniaturowe z węglika spiekanego dwuostrzowe z czolem kulistym do stali nierdzewnej
- Microfresa in MD per inox con raggio
- Microfresas de radio de metal duro para inoxidable

Artikel-Nr. Article-No.					E.7611.0
d1 +0,005	R	l2	l1	d2 h4	€ Stück piece
0,05	0,025	0,1	39	3,0	
0,10	0,050	0,2	39	3,0	
0,15	0,075	0,3	39	3,0	
0,20	0,100	0,4	39	3,0	
0,25	0,125	0,5	39	3,0	
0,30	0,150	0,6	39	3,0	
0,35	0,175	0,7	39	3,0	
0,40	0,200	0,8	39	3,0	
0,45	0,225	0,9	39	3,0	
0,50	0,250	1,0	39	3,0	
0,60	0,300	1,2	39	3,0	
0,70	0,350	1,4	39	3,0	
0,80	0,400	1,6	39	3,0	
0,90	0,450	1,8	39	3,0	
1,00	0,500	2,5	50	4,0	
1,10	0,550	2,5	50	4,0	
1,20	0,600	3,0	50	4,0	
1,30	0,650	3,0	50	4,0	
1,40	0,700	3,0	50	4,0	
1,50	0,750	4,0	50	4,0	
1,60	0,800	4,0	50	4,0	
1,70	0,850	4,0	50	4,0	
1,80	0,900	5,0	50	4,0	
1,90	0,950	5,0	50	4,0	
2,00	1,000	6,0	50	4,0	
2,10	1,050	6,0	50	4,0	
2,20	1,100	6,0	50	4,0	
2,30	1,150	7,0	50	4,0	
2,40	1,200	7,0	50	4,0	
2,50	1,250	7,0	50	4,0	
2,60	1,300	7,0	50	4,0	
2,70	1,350	7,0	50	4,0	
2,80	1,400	8,0	50	4,0	
2,90	1,450	8,0	50	4,0	
3,00	1,500	12,0	50	4,0	
3,50	1,750	12,0	50	4,0	
4,00	2,000	14,0	50	4,0	
4,50	2,250	14,0	50	5,0	
5,00	2,500	16,0	50	5,0	
6,00	3,000	19,0	64	6,0	

- Gewindebohrer 1
- Bohren HSSE 2
- Bohren VHM 3
- Reiben HSSE 4
- Reiben VHM 5
- Frässtifte VHM 6
- Inox 7
- WP-Werkzeuge 8
- Fräsen HSSE 9
- Sägen 10
- Lehren 11
- Nachschleifen 12
- Sonstiges 13

VHM-Inox-Advantage-Schaftfräser 48°

E.7693.1

2.1 2.2 4.1 4.2 4.4 4.7

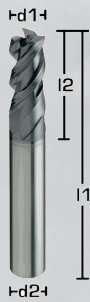
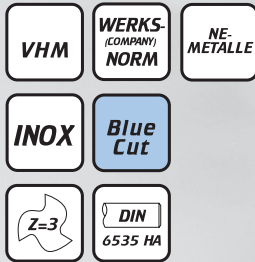

Solid carbide Inox Advantage end mills 48°

Frezy Advantage z węgla spiekane-go trzyostrzowe 48° do stali nierdzewnej

Frese in MD advantage inox 48°

Fresas de metal duro "Ventaja" de 48° para inoxidable

Artikel-Nr. Article-No.				E.7693.1 € Stück piece
d1	l2	l1	d2 h6	
1,00	4	57	6,0	
2,00	6	57	6,0	
3,00	8	57	6,0	
4,00	11	57	6,0	
5,00	13	57	6,0	
6,00	13	57	6,0	
8,00	19	63	8,0	
10,00	22	72	10,0	
12,00	26	83	12,0	
16,00	32	92	16,0	
20,00	38	104	20,0	

VHM-Inox-Schlichtfräser 45°

E.7673.1

2.1 2.2 4.1 4.2 4.4 4.7

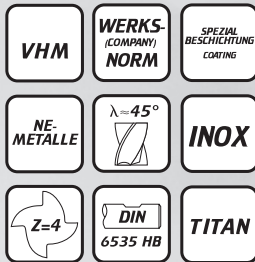

Solid carbide Inox finishing end mills 45°

Frezy z węgla spiekane-go czte-rostrzowe 45° do obróbki wykańczającej do stali nierdzewnej

Frese in MD per finitura inox 45°

Fresas de metal duro de acabado de 45° para inoxidable

Artikel-Nr. Article-No.				E.7673.1 € Stück piece
d1 h10	l2	l1	d2 h6	
6,00	13	57	6,0	
8,00	19	63	8,0	
10,00	22	72	10,0	
12,00	26	83	12,0	
16,00	32	92	16,0	
20,00	38	104	20,0	

VHM-Inox-Schlichtfräser 60°

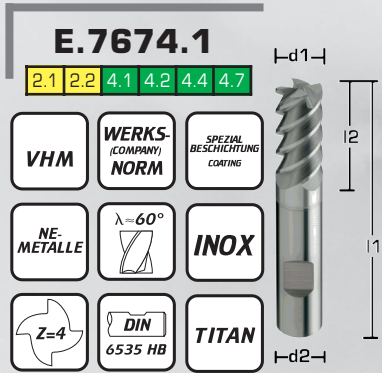

E.7674.1

2.1 2.2 4.1 4.2 4.4 4.7

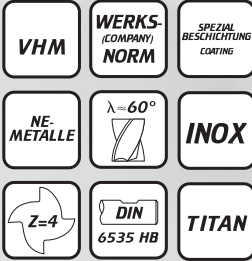

- Solid carbide Inox finishing end mills 60°
- Frezy z węgla spiekane go czte-roostrzowe 60° do obróbki wykańczającej do stali nierdzewnej
- Frese in MD per finitura inox 60°
- Fresas de metal duro de acabado de 60° para inoxidable

Für dünnwandige Bearbeitung
Working at thin walls

Artikel-Nr. Article-No.				E.7674.1 € Stück piece
d1 h10	l2	l1	d2 h6	
6,00	13	57	6,0	
8,00	19	63	8,0	
10,00	22	72	10,0	
12,00	26	83	12,0	
16,00	32	92	16,0	
18,00	32	92	18,0	
20,00	38	104	20,0	



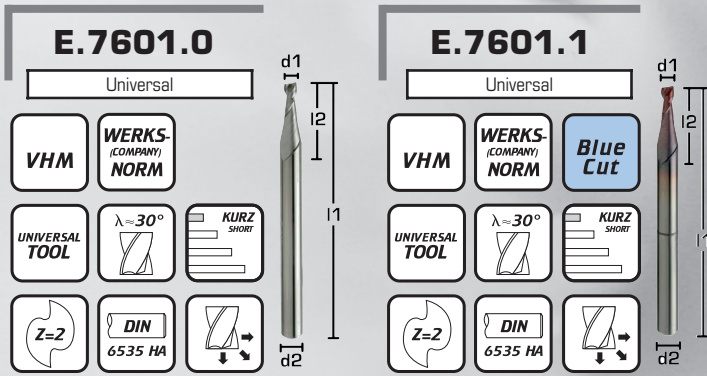

- Gewindebohrer 1
- Bohren HSSE 2
- Bohren VHM 3
- Reiben HSSE 4
- Reiben VHM 5
- Frässtifte VHM 6
- Inox 7
- WP-Werkzeuge 8
- Fräsen HSSE 9
- Sägen 10
- Lehren 11
- Nachschleifen 12
- Sonstiges 13

VHM-Universal-Mikroschaftfräser 30° kurz



 Solid carbide Universal micro end mills 30° short

 Frezy miniaturowe z węgla spiekane go dwuostrzowe krótkie 30° uniwersalne





 Microfresse in MD universale 30° corta

 Microfresas de metal duro de 30°, uso universal, serie corta

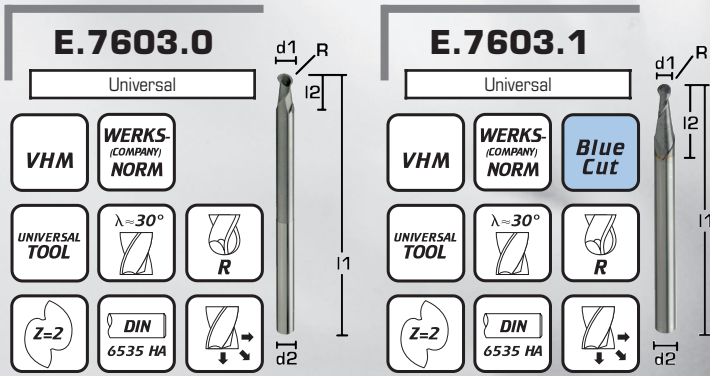
Artikel-Nr. Article-No.				E.7601.0	E.7601.1
d1	l2	l1	d2 h6	€ Stück piece	€ Stück piece
0,10	0,30	38	3,0		
0,15	0,30	38	3,0		
0,20	0,50	38	3,0		
0,25	0,50	38	3,0		
0,30	1,00	38	3,0		
0,40	1,00	38	3,0		
0,50	1,50	38	3,0		
0,60	1,50	38	3,0		
0,70	2,00	38	3,0		
0,80	2,00	38	3,0		
0,90	2,50	38	3,0		
1,00	3,00	38	3,0		
1,10	3,00	38	3,0		
1,20	4,00	38	3,0		
1,30	4,00	38	3,0		
1,40	4,00	38	3,0		
1,50	4,00	38	3,0		
1,60	4,00	38	3,0		
1,70	4,00	38	3,0		
1,80	5,00	38	3,0		
1,90	5,00	38	3,0		
2,00	5,00	38	3,0		

VHM-Universal-Mikroradiusfräser 30°



-  Solid carbide Universal micro ball nose end mills 30°
-  Frezy miniaturowe z węglika spiekanego dwuostrzowe 30° z czotem kulistym uniwersalne
-  Microfresa in MD raggiata universale 30°
-  Microfresas de radio de metal duro de 30°, uso universal

Artikel-Nr. Article-No.					E.7603.0	E.7603.1
d1	R	l2	l1	d2 h6	€ Stück piece	€ Stück piece
0,10	0,050	0,2	38	3,0		
0,15	0,075	0,3	38	3,0		
0,20	0,100	0,5	38	3,0		
0,25	0,125	0,5	38	3,0		
0,30	0,150	1,0	38	3,0		
0,40	0,200	1,0	38	3,0		
0,50	0,250	1,5	38	3,0		
0,60	0,300	1,5	38	3,0		
0,70	0,350	2,0	38	3,0		
0,80	0,400	2,0	38	3,0		
0,90	0,450	2,5	38	3,0		
1,00	0,500	3,0	38	3,0		
1,10	0,550	3,0	38	3,0		
1,20	0,600	3,0	38	3,0		
1,40	0,700	4,0	38	3,0		
1,50	0,750	4,0	38	3,0		
1,60	0,800	5,0	38	3,0		
1,80	0,900	5,0	38	3,0		
2,00	1,000	5,0	38	3,0		
2,50	1,250	7,0	38	3,0		

Gewindebohrer	1
Bohren HSSE	2
Bohren VHM	3
Reiben HSSE	4
Reiben VHM	5
Frässtifte VHM	6
Universal	7
WP-Werkzeuge	8
Fräsen HSSE	9
Sägen	10
Lehren	11
Nachschleifen	12
Sonstiges	13

E.7606.0

Universal



Solid carbide Universal end mills 30°

Frezy z węgla spiekanego dwuostrzowe 30° uniwersalne

Frese in MD universale 30°

Fresas de metal duro de 30°, uso universal

Artikel-Nr. Article-No.				E.7606.0 € Stück piece
d1	l2	l1	d2 h6	
2,00	8,0	38	2,0	
2,50	8,0	38	2,5	
3,00	12,0	38	3,0	
3,50	12,0	40	3,5	
4,00	12,0	40	4,0	
4,50	14,0	50	4,5	
5,00	14,0	50	5,0	
5,50	16,0	50	5,5	
6,00	16,0	50	6,0	
6,50	16,0	50	6,5	
7,00	20,0	60	7,0	
7,50	20,0	60	7,5	
8,00	20,0	60	8,0	
8,50	20,0	60	8,5	
9,00	20,0	60	9,0	
9,50	22,0	70	9,5	
10,00	22,0	70	10,0	
11,00	22,0	70	11,0	
12,00	22,0	70	12,0	
13,00	25,0	75	13,0	
14,00	25,0	75	14,0	
15,00	25,0	75	15,0	
16,00	25,0	75	16,0	
18,00	32,0	100	18,0	
20,00	32,0	100	20,0	
lang long				E.7606.0L
3,00	20,0	55	3,0	
4,00	20,0	60	4,0	
5,00	20,0	60	5,0	
6,00	24,0	65	6,0	
8,00	32,0	80	8,0	
10,00	32,0	80	10,0	
12,00	50,0	100	12,0	
14,00	50,0	100	14,0	
16,00	50,0	100	16,0	
18,00	50,0	100	18,0	
20,00	50,0	100	20,0	
überlang extended long				E.7606.0XL
3,00	30,0	70	3,0	
4,00	40,0	75	4,0	
5,00	40,0	80	5,0	
6,00	45,0	80	6,0	
8,00	50,0	100	8,0	
10,00	50,0	100	10,0	
12,00	70,0	150	12,0	
14,00	75,0	150	14,0	
16,00	75,0	150	16,0	
18,00	75,0	150	18,0	
20,00	75,0	150	20,0	

VHM-Universal-Schaftfräser 30° kurz

E.7613.1

Universal

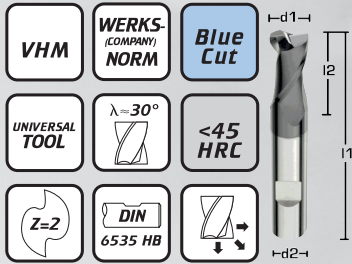

Solid carbide Universal end mills 30° short

Frezy z węgla spiekanego dwuostrzowe krótkie 30° uniwersalne

Frese in MD universale 30° corte

Fresas de metal duro de 30°, uso universal, serie corta

Artikel-Nr. Article-No.

d1	l2	l1	d2	E.7613.1 € Stück piece
2,00	3	38	3,0	
3,00	4	38	3,0	
4,00	5	54	6,0	
5,00	6	54	6,0	
6,00	7	54	6,0	
8,00	9	58	8,0	
10,00	11	66	10,0	
12,00	12	73	12,0	
14,00	14	75	14,0	
16,00	16	82	16,0	
18,00	18	84	18,0	
20,00	20	92	20,0	

VHM-Universal-Schaftfräser 30° kurz

E.7666.1

Universal

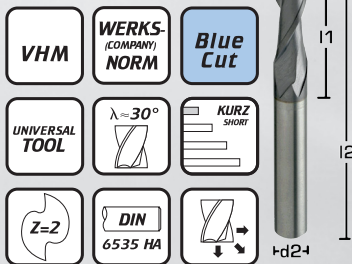

Solid carbide Universal end mills 30° short

Frezy z węgla spiekanego dwuostrzowe krótkie 30° uniwersalne

Frese in MD universale 30° corte

Fresas de metal duro de 30°, uso universal, serie corta

Artikel-Nr. Article-No.

d1 h10	l2	l1	d2 h6	E.7666.1 € Stück piece
1,00	5	50	6,0	
2,00	6	50	6,0	
3,00	6	50	6,0	
4,00	8	50	6,0	
5,00	8	50	6,0	
6,00	16	50	6,0	
8,00	20	60	8,0	
10,00	22	70	10,0	
12,00	22	70	12,0	
16,00	25	75	16,0	
20,00	32	100	20,0	

- Gewindebohrer 1
- Bohren HSSE 2
- Bohren VHM 3
- Reiben HSSE 4
- Reiben VHM 5
- Frässtifte VHM 6
- Universal 7
- WP-Werkzeuge 8
- Fräsen HSSE 9
- Sägen 10
- Lehren 11
- Nachtschleifen 12
- Sonstiges 13

VHM-Universal-Schaftfräser 30° lang

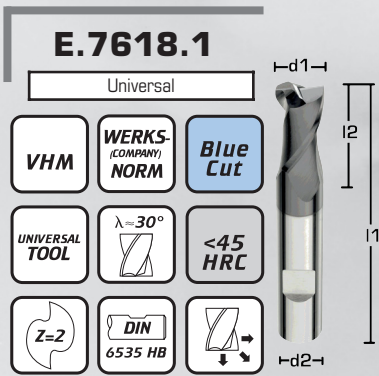

Solid carbide Universal end mills 30° long

Frezy z węgliką spiekanego dwuostrzowe długie 30° uniwersalne

Frese in MD universale 30° lunga

Fresas de metal duro de 30°, uso universal, serie larga

Artikel-Nr. Article-No.				E.7618.1 € Stück piece
d1	l2	l1	d2	
2,00	6	38	3,0	
2,50	6	38	3,0	
3,00	7	38	3,0	
3,50	8	57	6,0	
4,00	8	57	6,0	
4,50	10	57	6,0	
4,70	10	57	6,0	
5,00	10	57	6,0	
5,50	10	57	6,0	
5,70	10	57	6,0	
6,00	10	57	6,0	
7,00	16	63	8,0	
7,70	16	63	8,0	
8,00	16	63	8,0	
9,70	19	72	10,0	
10,00	19	72	10,0	
11,70	22	83	12,0	
12,00	22	83	12,0	
13,70	22	83	14,0	
14,00	22	83	14,0	
15,70	26	92	16,0	
16,00	26	92	16,0	
18,00	26	92	18,0	
20,00	32	104	20,0	

VHM-Universal-Schaftfräser 30° mit Eckenradius lang

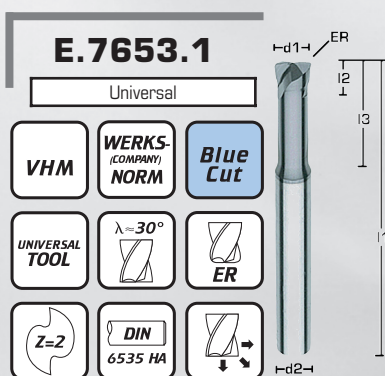

Solid carbide Universal end mills 30° with corner radius long

Frezy z węgliką spiekanego dwuostrzowe długie 30° z promieniem na czole uniwersalne

Frese in MD universale 30°, con raggio d'angolo, serie lunga

Fresas de metal duro con radio lateral de 30°, uso universal, serie larga

Speziell geeignet zum Fräsen mit geringer Schnitttiefe
Specially suited for milling with minimum cutting depth

Artikel-Nr. Article-No.						E.7653.1 € Stück piece
d1 0/-0,04	ER	l2	l3	l1	d2 h6	
6,00	0,4	2,5	42	85	5,0	
8,00	0,6	3,0	42	85	7,0	
10,00	0,7	3,0	42	85	9,0	
12,00	0,9	4,5	42	85	11,0	
16,00	1,0	5,5	70	110	15,0	

VHM-Universal-Schaftfräser 30° mit Eckenradius XL

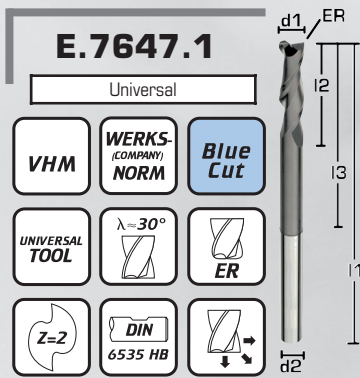

E.7647.1

Universal



Solid carbide Universal end mills 30° with corner radius XL

Frezy z węgla spiekane go dwuostrzowe bardzo długie 30° z promieniem na czole uniwersalne

Frese in MD universale 30°, con raggio d'angolo, serie extra lunga

Fresas de metal duro con radio lateral de 30°, uso universal, serie extra larga

Artikel-Nr. Article-No.						E.7647.1
d1	ER	l2	l3	l1	d2	€ Stück piece
6,00	0,3	25	120	200	6,0	
8,00	0,3	25	120	200	8,0	
10,00	0,3	50	120	200	10,0	
12,00	0,4	50	120	200	12,0	
16,00	0,4	65	150	220	16,0	
20,00	0,4	65	150	250	20,0	

VHM-Universal-Kugelfräser 30°

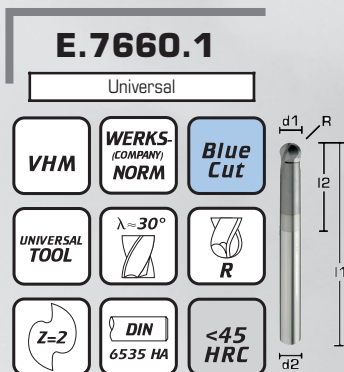

E.7660.1

Universal



Solid carbide Universal ball nose end mills 30°

Frezy z węgla spiekane go dwuostrzowe 30° z czolem kulistym uniwersalne

Frese in MD universale 30° raggiata

Fresas de bola de metal duro de 30°, uso universal

Artikel-Nr. Article-No.					E.7660.1
d1	R	l2	l1	d2	€ Stück piece
3,00	1,5	7	60	2,1	
4,00	2,0	9	60	2,8	
5,00	2,5	12	60	3,5	
6,00	3,0	15	70	4,3	
8,00	4,0	21	70	5,7	
10,00	5,0	25	70	7,0	
12,00	6,0	30	90	8,5	

- 1 Gewindebohrer
- 2 Bohren HSSE
- 3 Bohren VHM
- 4 Reiben HSSE
- 5 Reiben VHM
- 6 Frässtifte VHM
- 7 Universal
- 8 WP-Werkzeuge
- 9 Fräsen HSSE
- 10 Sägen
- 11 Lehren
- 12 Nachschleifen
- 13 Sonstiges

VHM-Universal-Radiusfräser 30°

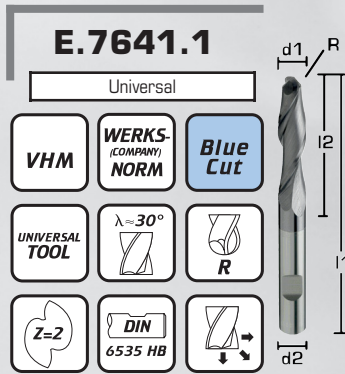

Solid carbide Universal ball nose end mills 30°

Frezy z węgla spiekanego dwuostrzowe 30° z czodem kulistym uniwersalne





Frese in MD universale 30° raggiata

Fresas de radio de metal duro de 30°, uso universal

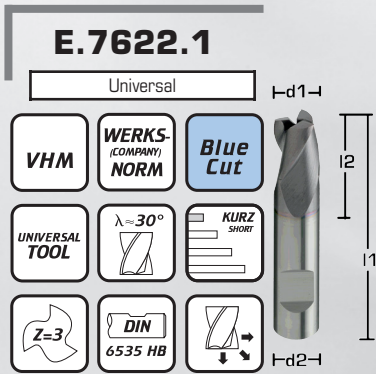
Artikel-Nr. Article-No.					E.7641.1 € Stück piece
d1	R	l2	l1	d2 h6	
1,00	0,50	3	50	6,0	
2,00	1,00	4	50	6,0	
2,50	1,25	4	50	6,0	
3,00	1,50	5	50	6,0	
3,50	1,75	5	50	6,0	
4,00	2,00	6	54	6,0	
4,50	2,25	6	54	6,0	
5,00	2,50	7	54	6,0	
6,00	3,00	9	54	6,0	
8,00	4,00	12	58	8,0	
10,00	5,00	14	66	10,0	
12,00	6,00	14	73	12,0	
14,00	7,00	16	75	14,0	
16,00	8,00	18	82	16,0	
18,00	9,00	20	88	18,0	
20,00	10,00	22	92	20,0	
lang long					E.7641.1L
3,00	1,50	20	60	3,0	
4,00	2,00	25	60	4,0	
5,00	2,50	25	75	5,0	
6,00	3,00	30	75	6,0	
8,00	4,00	45	100	8,0	
10,00	5,00	45	100	10,0	
12,00	6,00	45	100	12,0	
16,00	8,00	45	100	16,0	
20,00	10,00	45	100	20,0	
überlang extended long					E.7641.1XL
6,00	3,00	40	150	6,0	
8,00	4,00	40	150	8,0	
10,00	5,00	40	150	10,0	
12,00	6,00	50	150	12,0	
16,00	8,00	50	150	16,0	
20,00	10,00	50	150	20,0	
25,00	12,50	50	150	25,0	
extra lang extra long					E.7641.1XXL
8,00	4,00	40	200	8,0	
10,00	5,00	40	200	10,0	
12,00	6,00	40	200	12,0	
16,00	8,00	60	200	16,0	
20,00	10,00	80	200	20,0	
25,00	12,50	80	200	25,0	
super lang super long					E.7641.1SL
6,00	3,00	25	200	6,0	
8,00	4,00	25	200	8,0	
10,00	5,00	50	200	10,0	
12,00	6,00	50	200	12,0	
16,00	8,00	65	220	16,0	
20,00	10,00	65	250	20,0	

VHM-Universal-Einweg-Schaftfräser 30°





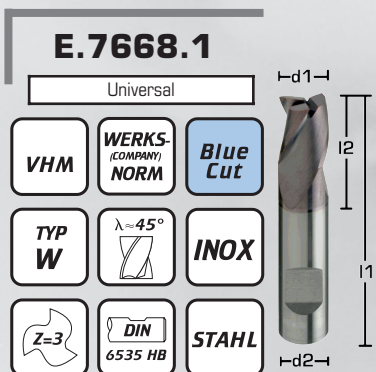

-  Solid carbide Universal throw away end mills 30°
-  Frezy z węgliką spiekanego trzyostrzowe 30° z ostrzami na czole uniwersalne
-  Frese in MD a gettare 30°
-  Fresas de metal duro de 30°, uso universal de un solo uso

Artikel-Nr. Article-No.				E.7622.1 € Stück piece
d1 h10	l2	l1	d2 h6	
0,50	1,5	38	3,0	
1,00	2,0	38	3,0	
1,50	2,0	38	3,0	
2,00	4,0	38	6,0	
2,50	5,0	36	6,0	
3,00	5,0	38	6,0	
3,50	6,0	38	6,0	
4,00	7,0	38	6,0	
4,50	8,0	38	6,0	
5,00	8,0	38	6,0	
5,50	8,0	39	6,0	
5,75	8,0	39	6,0	
6,00	8,0	38	6,0	
7,00	10,0	42	8,0	
8,00	11,0	43	8,0	
9,00	11,0	48	10,0	
10,00	13,0	50	10,0	
12,00	15,0	55	12,0	

VHM-Universal-Einweg-Schaftfräser 45°



-  Solid carbide Universal throw away end mills 45°
-  Frezy z węgliką spiekanego trzyostrzowe 45° z ostrzami na czole uniwersalne
-  Frese in MD a gettare 45°
-  Fresas de metal duro de 45°, uso universal de un solo uso

Artikel-Nr. Article-No.				E.7668.1 € Stück piece
d1	l2	l1	d2 h6	
1,00	4	38	6,0	
2,00	4	38	6,0	
3,00	5	38	6,0	
4,00	7	38	6,0	
5,00	8	38	6,0	
6,00	8	38	6,0	
8,00	11	43	8,0	
10,00	13	50	10,0	

- Gewindebohrer 1
- Bohren HSSE 2
- Bohren VHM 3
- Reiben HSSE 4
- Reiben VHM 5
- Frässtifte VHM 6
- Universal 7
- WP-Werkzeuge 8
- Fräsen HSSE 9
- Sägen 10
- Lehren 11
- Nachschleifen 12
- Sonstiges 13

E.7626.0

Universal

↳d1↳



 Solid carbide Universal end mills 30°

 Frezy z węgla spiekanego trzyostrzowe 30° uniwersalne

 Frese in MD universali 30°

 Fresas de metal duro de 30°, uso universal

Artikel-Nr. Article-No.				E.7626.0 € Stück piece
d1	l2	l1	d2 h6	
2,00	8,0	38	2,0	
2,50	8,0	38	2,5	
3,00	12,0	38	3,0	
3,50	12,0	40	3,5	
4,00	12,0	40	4,0	
4,50	14,0	50	4,5	
5,00	14,0	50	5,0	
5,50	16,0	50	5,5	
6,00	16,0	50	6,0	
6,50	16,0	50	6,5	
7,00	20,0	60	7,0	
7,50	20,0	60	7,5	
8,00	20,0	60	8,0	
8,50	20,0	60	8,5	
9,00	20,0	60	9,0	
9,50	22,0	70	9,5	
10,00	22,0	70	10,0	
11,00	22,0	70	11,0	
12,00	22,0	70	12,0	
13,00	25,0	75	13,0	
14,00	25,0	75	14,0	
15,00	25,0	75	15,0	
16,00	25,0	75	16,0	
18,00	32,0	100	18,0	
20,00	32,0	100	20,0	
lang long				E.7626.0L
3,00	20,0	55	3,0	
4,00	20,0	60	4,0	
5,00	20,0	60	5,0	
6,00	24,0	65	6,0	
8,00	32,0	80	8,0	
10,00	32,0	80	10,0	
12,00	50,0	100	12,0	
14,00	50,0	100	14,0	
16,00	50,0	100	16,0	
18,00	50,0	100	18,0	
20,00	50,0	100	20,0	
überlang extended long				E.7626.0XL
3,00	30,0	70	3,0	
4,00	40,0	75	4,0	
5,00	40,0	80	5,0	
6,00	45,0	80	6,0	
8,00	50,0	100	8,0	
10,00	50,0	100	10,0	
12,00	70,0	150	12,0	
14,00	75,0	150	14,0	
16,00	75,0	150	16,0	
18,00	75,0	150	18,0	
20,00	75,0	150	20,0	

VHM-Universal-Schaftfräser 30° kurz

E.7623.1

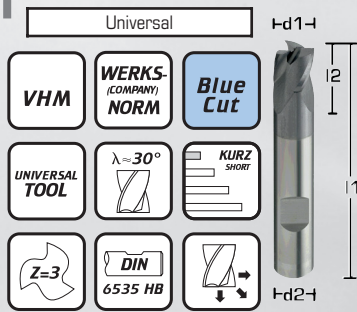

Solid carbide Universal end mills 30° short

Frezy z węgla spiekanego trzyostrzowe krótkie 30° uniwersalne

Frese in MD universali 30° corte

Fresas de metal duro de 30°, uso universal, serie corta

Artikel-Nr. Article-No.				E.7623.1 € Stück piece
d1 h10	l2	l1	d2 h6	
1,00	5	50	6,0	
2,00	6	50	6,0	
3,00	6	50	6,0	
4,00	8	50	6,0	
5,00	8	50	6,0	
6,00	16	50	6,0	
8,00	20	60	8,0	
10,00	22	70	10,0	
12,00	22	70	12,0	
16,00	25	75	16,0	
20,00	32	100	20,0	

VHM-Universal-Schaftfräser 30° lang

E.7624.1

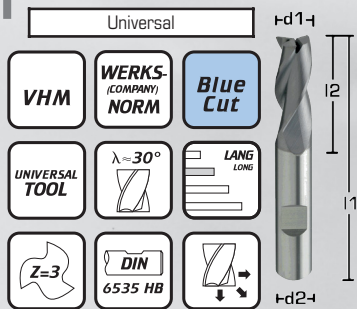

Solid carbide Universal end mills 30° long

Frezy z węgla spiekanego trzyostrzowe długie 30° uniwersalne

Frese in MD universali 30° lunghe

Fresas de metal duro de 30°, uso universal, serie larga

Artikel-Nr. Article-No.				E.7624.1 € Stück piece
d1	l2	l1	d2 h6	
1,00	6	57	6,0	
1,50	7	57	6,0	
2,00	6	57	6,0	
2,50	7	57	6,0	
3,00	7	57	6,0	
3,50	8	57	6,0	
4,00	8	57	6,0	
5,00	10	57	6,0	
5,50	10	57	6,0	
6,00	10	57	6,0	
8,00	16	63	8,0	
10,00	19	72	10,0	
12,00	22	83	12,0	
14,00	22	83	14,0	
16,00	26	92	16,0	
18,00	26	92	18,0	
20,00	32	104	20,0	
22,00	40	100	22,0	
25,00	60	150	25,0	
32,00	60	150	32,0	
40,00	60	150	40,0	

- Gewindebohrer 1
- Bohren HSSE 2
- Bohren VHM 3
- Reiben HSSE 4
- Reiben VHM 5
- Frässtifte VHM 6
- Universal 7
- WP-Werkzeuge 8
- Fräsen HSSE 9
- Sägen 10
- Lehren 11
- Nachschleifen 12
- Sonstiges 13

VHM-Universal-Bohrnutenfräser 30° mit Untermaß

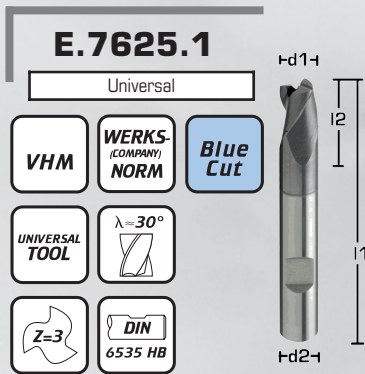

Solid carbide Universal center cut end mills 30° with undersize

Frezy z węgla spiek. trzyostrzowe 30° z przesuniętym ostrzem na czole poza oś freza - do frezowania rowków

Frese in MD universali 30° minorate

Fresas de metal duro de dos labios de 30° con medida rebajada para uso universal

Artikel-Nr. Article-No.				E.7625.1 € Stück piece
d1	l2	l1	d2 h6	
1,80	3	50	6,0	
2,80	4	50	6,0	
3,80	5	50	6,0	
4,80	6	50	6,0	
5,75	7	50	6,0	
6,70	8	50	8,0	
7,75	10	60	8,0	
8,70	10	70	12,0	
9,70	11	70	12,0	

VHM-Universal-Schaftfräser 30° linksschneidend

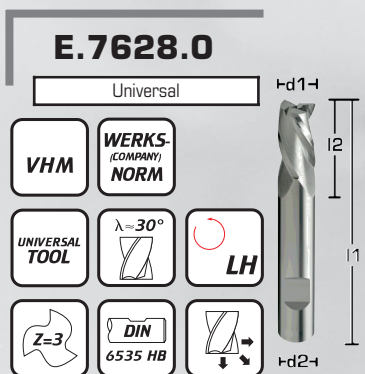

Solid carbide Universal end mills 30° LH-cutting

Frezy z węgla spiek. trzyostrzowe 30° lewoskrętne uniwersalne

Frese in MD universali 30° elica sx

Fresas de metal duro de 30°, uso universal, corte izquierdo

Artikel-Nr. Article-No.				E.7628.0 € Stück piece
d1	l2	l1	d2 h6	
4,00	10	57	6,0	
5,00	10	57	6,0	
6,00	10	57	6,0	
8,00	16	63	8,0	
9,00	19	72	10,0	
10,00	19	72	10,0	
12,00	22	83	12,0	

VHM-Universal-Schaftfräser 45° kurz

E.7631.1

Universal

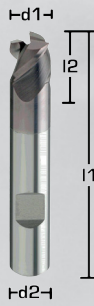

Solid carbide Universal end mills 45° short

Frezy z węgla spiekanego trzyostrzowe 45° krótkie uniwersalne

Frese in MD universali 45° corta

Fresas de metal duro de 45°, uso universal, serie corta

Artikel-Nr. Article-No.

E.7631.1

€

Stück piece

d1	l2	l1	d2 h6	
3,00	4	50	6,0	
4,00	5	54	6,0	
5,00	6	54	6,0	
6,00	7	54	6,0	
8,00	9	58	8,0	
10,00	11	66	10,0	
12,00	12	73	12,0	
14,00	14	75	14,0	
16,00	16	82	16,0	
20,00	20	92	20,0	
25,00	32	104	25,0	

VHM-Universal-Schaftfräser 45° lang

E.7632.1

Universal



Solid carbide Universal end mills 45° long

Frezy z węgla spiekanego trzyostrzowe długie 45° uniwersalne

Frese in MD universali 45° lunghe

Fresas de metal duro de 45°, uso universal, serie larga

Artikel-Nr. Article-No.

E.7632.1

€

Stück piece

d1	l2	l1	d2 h6	
1,00	5	57	6,0	
2,00	6	57	6,0	
3,00	7	57	6,0	
3,50	8	57	6,0	
4,00	8	57	6,0	
4,50	10	57	6,0	
5,00	10	57	6,0	
5,50	10	57	6,0	
6,00	10	57	6,0	
7,00	16	63	8,0	
8,00	19	63	8,0	
9,00	19	72	10,0	
10,00	19	72	10,0	
12,00	22	83	12,0	
14,00	22	83	14,0	
16,00	26	92	16,0	
18,00	26	92	18,0	
20,00	32	104	20,0	

- Gewindebohrer 1
- Bohren HSSE 2
- Bohren VHM 3
- Reiben HSSE 4
- Reiben VHM 5
- Frässtifte VHM 6
- Universal 7
- WP-Werkzeuge 8
- Fräsen HSSE 9
- Sägen 10
- Lehren 11
- Nachschleifen 12
- Sonstiges 13

VHM-Universal-Schaftfräser 60°

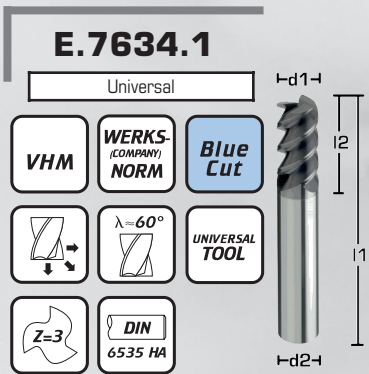

Solid carbide Universal end mills 60°

Frezy z węgla spiekane go trzostrzowe 60° uniwersalne

Frese in MD universali 60°

Fresas de metal duro de 60°, uso universal

Artikel-Nr. Article-No.				E.7634.1 € Stück piece
d1	l2	l1	d2 h6	
4,00	12	50	6,0	
5,00	14	50	6,0	
6,00	16	50	6,0	
8,00	20	60	8,0	
10,00	22	70	10,0	
12,00	22	70	12,0	
14,00	25	75	14,0	
16,00	25	75	16,0	
18,00	30	100	18,0	
20,00	30	100	20,0	

VHM-Universal-Schaftfräser 30° extra kurz

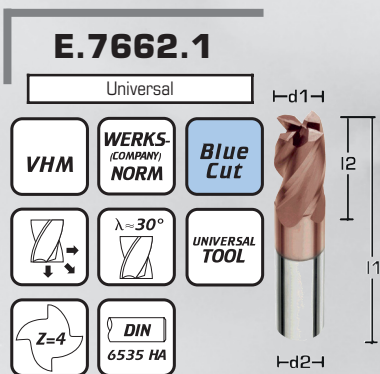

Solid carbide Universal end mills 30° extra short

Frezy z węgla spiekane go czterostrzowe bardzo krótkie 30° uniwersalne

Frese in MD universali 30° extra corte

Fresas de metal duro de 30°, uso universal, serie extra corta

Artikel-Nr. Article-No.				E.7662.1 € Stück piece
d1	l2	l1	d2 h6	
1,00	2,0	38	3,0	
1,50	3,0	38	3,0	
1,60	3,0	38	3,0	
2,00	4,0	38	3,0	
2,50	5,0	38	3,0	
3,00	6,0	38	3,0	
3,50	7,0	50	4,0	
4,00	8,0	50	4,0	
4,50	9,5	50	5,0	
5,00	10,0	50	5,0	
6,00	12,0	50	6,0	
8,00	12,0	50	8,0	
10,00	16,0	50	10,0	
12,00	19,0	63	12,0	
16,00	32,0	89	16,0	

E.7648.0

Universal



Solid carbide Universal end mills 30°

Frezy z węgla spiekanego czterostrzowe 30° uniwersalne

Frese in MD universali 30°

Fresas de metal duro de 30°, uso universal

Artikel-Nr. Article-No.				E.7648.0
d1	l2	l1	d2 h6	€ Stück piece
2,00	8,0	38	2,0	
2,50	8,0	38	2,5	
3,00	12,0	38	3,0	
3,50	12,0	40	3,5	
4,00	12,0	40	4,0	
4,50	14,0	50	4,5	
5,00	14,0	50	5,0	
5,50	16,0	50	5,5	
6,00	16,0	50	6,0	
6,50	16,0	50	6,5	
7,00	20,0	60	7,0	
7,50	20,0	60	7,5	
8,00	20,0	60	8,0	
8,50	20,0	60	8,5	
9,00	20,0	60	9,0	
9,50	22,0	70	9,5	
10,00	22,0	70	10,0	
11,00	22,0	70	11,0	
12,00	22,0	70	12,0	
13,00	25,0	75	13,0	
14,00	25,0	75	14,0	
15,00	25,0	75	15,0	
16,00	25,0	75	16,0	
18,00	32,0	100	18,0	
20,00	32,0	100	20,0	
lang long				E.7648.0L
3,00	20,0	55	3,0	
4,00	20,0	60	4,0	
5,00	20,0	60	5,0	
6,00	24,0	65	6,0	
8,00	32,0	80	8,0	
10,00	32,0	80	10,0	
12,00	50,0	100	12,0	
14,00	50,0	100	14,0	
16,00	50,0	100	16,0	
18,00	50,0	100	18,0	
20,00	50,0	100	20,0	
überlang extended long				E.7648.0XL
3,00	30,0	70	3,0	
4,00	40,0	75	4,0	
5,00	40,0	80	5,0	
6,00	45,0	80	6,0	
8,00	50,0	100	8,0	
10,00	50,0	100	10,0	
12,00	70,0	150	12,0	
14,00	75,0	150	14,0	
16,00	75,0	150	16,0	
18,00	75,0	150	18,0	
20,00	75,0	150	20,0	

- Gewindebohrer 1
- Bohren HSSE 2
- Bohren VHM 3
- Reiben HSSE 4
- Reiben VHM 5
- Frässtifte VHM 6
- Universal 7
- WP-Werkzeuge 8
- Fräsen HSSE 9
- Sägen 10
- Lehren 11
- Nachschleifen 12
- Sonstiges 13

VHM-Universal-Schaftfräser 30° kurz

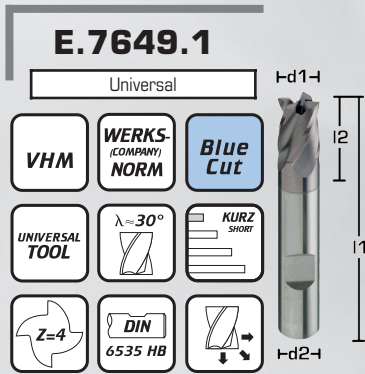

Solid carbide Universal end mills 30° short

Frezy z węgla spiekanego czteroostrzowe krótkie 30° uniwersalne

Frese in MD universali 30° corte

Fresas de metal duro de 30°, uso universal, serie corta

Artikel-Nr. Article-No.				E.7649.1 € Stück piece
d1	l2	l1	d2	
2,00	4	38	3,0	
3,00	5	38	3,0	
4,00	8	54	6,0	
5,00	9	54	6,0	
6,00	10	54	6,0	
8,00	12	58	8,0	
10,00	14	66	10,0	
12,00	16	73	12,0	
14,00	18	75	14,0	
16,00	22	82	16,0	
18,00	24	84	18,0	
20,00	26	92	20,0	

VHM-Universal-Schaftfräser 30° lang

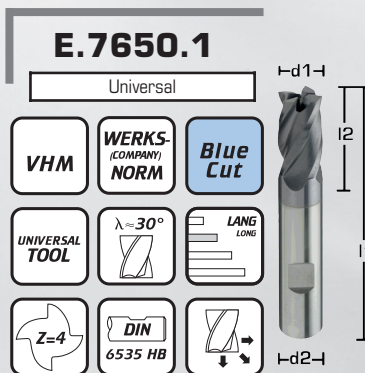

Solid carbide Universal end mills 30° long

Frezy z węgla spiekanego czteroostrzowe długie 30° uniwersalne

Frese in MD universali 30° lunghe

Fresas de metal duro de 30°, uso universal, serie larga

Artikel-Nr. Article-No.				E.7650.1 € Stück piece
d1	l2	l1	d2 h6	
1,00	3	38	3,0	
2,00	7	38	3,0	
3,00	8	38	3,0	
4,00	11	57	6,0	
5,00	13	57	6,0	
6,00	13	57	6,0	
8,00	19	63	8,0	
10,00	22	72	10,0	
12,00	26	83	12,0	
14,00	26	83	14,0	
16,00	32	92	16,0	
18,00	32	92	18,0	
20,00	38	104	20,0	
22,00	40	100	22,0	
25,00	60	150	25,0	
32,00	60	150	32,0	
40,00	60	150	40,0	

VHM-Universal-Schaftfräser 45° kurz

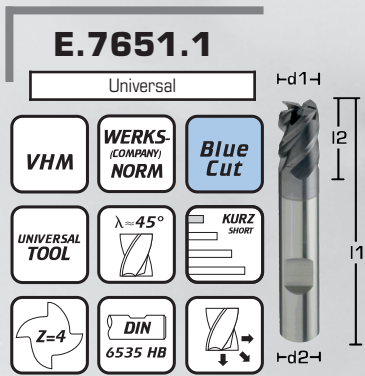

Solid carbide Universal end mills 45° short

Frezy z węgla spiekanego cztero-rostrzowe krótkie 45° uniwersalne

Frese in MD universali 45° corte

Fresas de metal duro de 45°, uso universal, serie corta

Artikel-Nr. Article-No.				E.7651.1 € Stück piece
d1	l2	l1	d2 h6	
3,00	5	50	6,0	
4,00	8	54	6,0	
5,00	9	54	6,0	
6,00	10	54	6,0	
8,00	12	58	8,0	
10,00	14	66	10,0	
12,00	16	73	12,0	
14,00	18	75	14,0	
16,00	22	82	16,0	
20,00	26	92	20,0	

VHM-Universal-Schaftfräser 45° lang

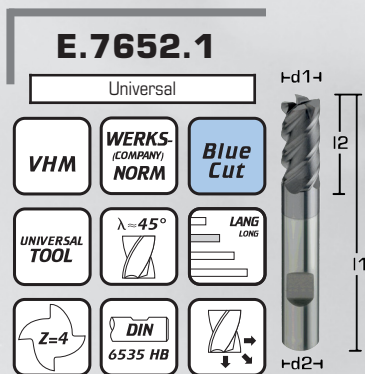

Solid carbide Universal end mills 45° long

Frezy z węgla spiekanego cztero-rostrzowe długie 45° uniwersalne

Frese in MD universali 45° lunghe

Fresas de metal duro de 45°, uso universal, serie larga

Artikel-Nr. Article-No.				E.7652.1 € Stück piece
d1	l2	l1	d2 h6	
3,00	8	57	6,0	
4,00	11	57	6,0	
5,00	13	57	6,0	
6,00	13	57	6,0	
8,00	19	63	8,0	
10,00	22	72	10,0	
12,00	26	83	12,0	
14,00	26	83	14,0	
16,00	32	92	16,0	
18,00	32	92	18,0	
20,00	38	104	20,0	

- Gewindebohrer 1
- Bohren HSSE 2
- Bohren VHM 3
- Reiben HSSE 4
- Reiben VHM 5
- Frässtifte VHM 6
- Universal 7
- WP-Werkzeuge 8
- Fräsen HSSE 9
- Sägen 10
- Lehren 11
- Nachschleifen 12
- Sonstiges 13

VHM-Universal-Schaftfräser 45° extra lang

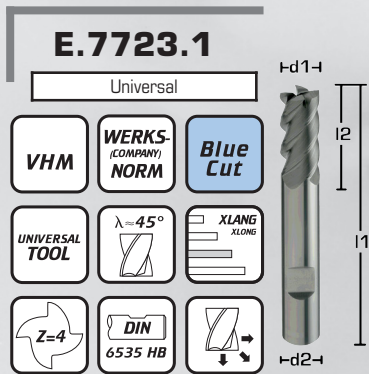

Solid carbide Universal end mills 45° extra long

Frezy z węgla spiekanego czterostrzowe bardzo długie 45° uniwersalne

Frese in MD universali 45° extra lunghe

Fresas de metal duro de 45°, uso universal, serie extra larga

Artikel-Nr. Article-No.				E.7723.1 € Stück piece
d1	l2	l1	d2 h6	
2,00	8	57	6,0	
3,00	14	57	6,0	
4,00	18	57	6,0	
5,00	20	57	6,0	
6,00	22	57	6,0	
8,00	30	63	8,0	
10,00	33	72	10,0	
12,00	34	83	12,0	
16,00	38	92	16,0	
20,00	47	104	20,0	

VHM-Universal-Schaftfräser 45° mit Eckenradius

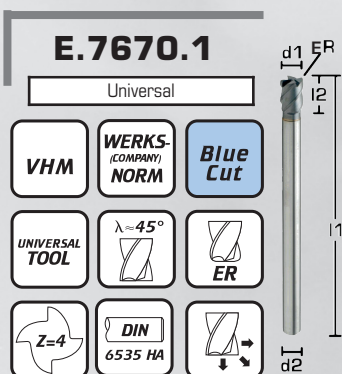

Solid carbide Universal end mills 45° with corner radius

Frezy z węgla spiekanego czterostrzowe 45° z promieniem na czole uniwersalne

Frese in MD universali 45° con raggio d'angolo

Fresas de metal duro de 45°, uso universal, con radio lateral

Artikel-Nr. Article-No.					E.7670.1 € Stück piece
d1	ER	l2	l1	d2	
7,00	0,5	9	120	6,0	
9,00	1,0	12	135	8,0	
11,00	1,0	15	150	10,0	
13,00	1,0	18	160	12,0	
17,00	1,5	24	180	16,0	

VHM-Universal-Radiusfräser 30°

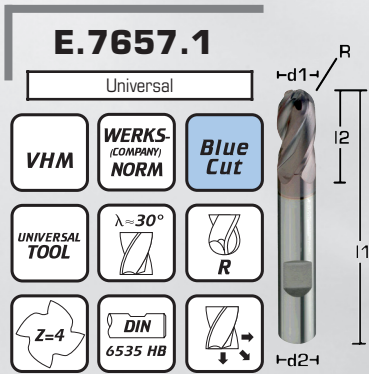

Solid carbide Universal ball nose end mills 30°

Frezy z węgla spiekanego cztero-rostrzowe 30° z czołem kulistym uniwersalne

Frese in MD universali raggate 30°

Fresas de metal duro de 30°, uso universal

Artikel-Nr. Article-No.					E.7657.1
d1	R	l2	l1	d2 h6	€ Stück piece
3,00	1,5	7	38	3,0	
4,00	2,0	14	50	4,0	
5,00	2,5	16	50	6,0	
6,00	3,0	19	60	6,0	
8,00	4,0	20	60	8,0	
10,00	5,0	21	70	10,0	
12,00	6,0	25	83	12,0	
16,00	8,0	32	88	16,0	
20,00	10,0	38	100	20,0	
lang long					E.7657.1L
3,00	1,5	20	60	3,0	
4,00	2,0	25	60	4,0	
5,00	2,5	25	75	5,0	
6,00	3,0	30	75	6,0	
8,00	4,0	45	100	8,0	
10,00	5,0	45	100	10,0	
12,00	6,0	45	100	12,0	
16,00	8,0	45	100	16,0	
20,00	10,0	45	100	20,0	
überlang extended long					E.7657.1XL
12,00	6,0	65	150	12,0	
16,00	8,0	65	150	16,0	
20,00	10,0	65	150	20,0	



- Gewindebohrer 1
- Bohren HSSE 2
- Bohren VHM 3
- Reiben HSSE 4
- Reiben VHM 5
- Frässtifte VHM 6
- Universal 7
- WP-Werkzeuge 8
- Fräsen HSSE 9
- Sägen 10
- Lehren 11
- Nachschleifen 12
- Sonstiges 13

VHM-Universal-Schaftfräser 30°

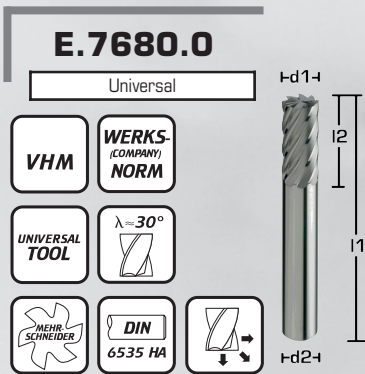

Solid carbide Universal end mills 30°

Frezy z węgla spiekane
wielostrzowe 30° uniwersalne

Frese in MD universali 30°

Fresas de metal duro de 30°, uso
universal

Artikel-Nr. Article-No.					E.7680.0 € Stück piece
d1	l2	l1	d2 h6	Zähne flutes	
3,00	12	38	3,0	6	
4,00	12	40	4,0	6	
5,00	14	50	5,0	6	
6,00	16	50	6,0	8	
7,00	20	60	7,0	8	
8,00	20	60	8,0	8	
10,00	22	70	10,0	8	
12,00	22	70	12,0	10	
16,00	25	75	16,0	12	

VHM-Universal-Schaftfräser 45°

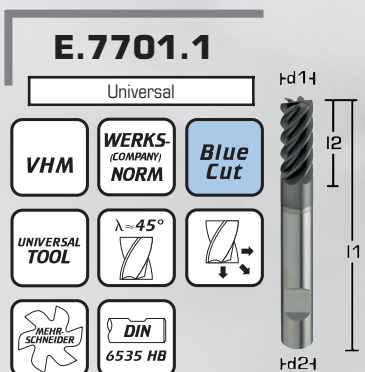

Solid carbide Universal end mills 45°

Frezy z węgla spiekane
wielostrzowe 45° uniwersalne

Frese in MD universali 45°

Fresas de metal duro de 45°, uso
universal

Artikel-Nr. Article-No.					E.7701.1 € Stück piece
d1	l2	l1	d2 h6	Zähne flutes	
4,00	11	57	6,0	6	
5,00	13	57	6,0	6	
6,00	13	57	6,0	6	
8,00	19	63	8,0	6	
10,00	22	72	10,0	6	
12,00	26	83	12,0	6	
16,00	32	92	16,0	6	
20,00	38	104	20,0	8	
lang long					E.7701.1L
4,00	16	62	6,0	6	
5,00	18	62	6,0	6	
6,00	18	62	6,0	6	
8,00	24	68	8,0	6	
10,00	30	80	10,0	6	
12,00	36	93	12,0	6	
16,00	48	108	16,0	6	
20,00	60	126	20,0	8	

VHM-Universal-Schaftfräser 45°

E.7681.1

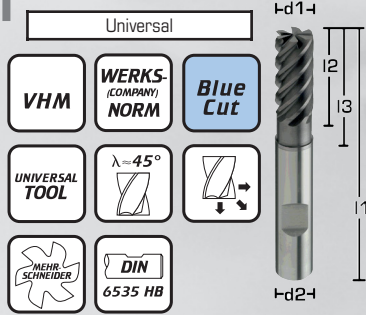

Solid carbide Universal end mills 45°

Frezy z węglika spiekanego wieloostrowe 45° uniwersalne

Frese in MD universali 45°

Fresas de metal duro de 45°, uso universal

Artikel-Nr. Article-No.						E.7681.1
d1	l2	l3	l1	d2 h6	Zähne flutes	€ Stück piece
5,00	13	18	57	6,0	6	
6,00	13	18	57	6,0	6	
8,00	19	24	63	8,0	6	
10,00	22	32	72	10,0	6	
12,00	26	36	83	12,0	6	
14,00	26	36	83	14,0	6	
16,00	32	42	92	16,0	6	
18,00	32	42	92	18,0	8	
20,00	38	48	104	20,0	8	
lang long						E.7681.1L
12,00	40		100	12,0	6	
16,00	60		150	16,0	6	
20,00	80		150	20,0	8	
25,00	60		150	25,0	8	

HM-bestückte Universal Schaftfräser 25°

E.7688.0

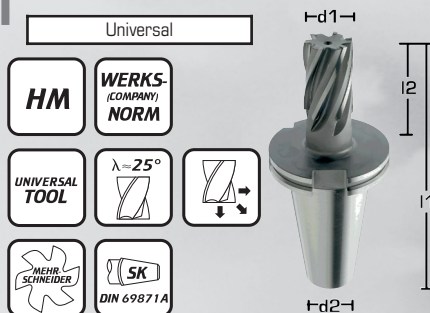

Carbide tipped Universal end mills 25°

Frezy wieloostrowe 25° uniwersalne z chwytem ze stali narzędziowej i ostrzem z węglika spiekanego

Frese in MD universali 45°, saldobrasate

Fresas con placas de metal duro de 25°, uso universal

Artikel-Nr. Article-No.					E.7688.0
d1 h10	l2	l1	d2 SK	Zähne flutes	€ Stück piece
40,00	63	183	40	6	
50,00	80	205	40	6	
40,00	63	215	50	6	
50,00	80	239	50	6	
50,00	150	309	50	6	
63,00	100	258	50	6	
63,00	200	359	50	6	
63,00	250	408	50	6	
80,00	200	359	50	8	
80,00	250	408	50	8	
80,00	300	459	50	8	

- 1 Gewindebohrer
- 2 Bohren HSSE
- 3 Bohren VHM
- 4 Reiben HSSE
- 5 Reiben VHM
- 6 Frässtifte VHM
- 7 Universal
- 8 WP-Werkzeuge
- 9 Fräsen HSSE
- 10 Sägen
- 11 Lehren
- 12 Nachschleifen
- 13 Sonstiges

VHM-Unispezial-Gravierstichel

E.6607.0

Universal



 Solid carbide Unispezial single lip cutters

 Frezy z węgla spiekane go jednostr-zowe do grawerowania stali

 Bulini in MD monospaccatae

 Buriles de metal duro unispecial

Artikel-Nr. Article-No.			E.6607.0 € Stück piece
d1	l2	l1	
2,00	3,0	50	
2,50	4,0	50	
3,00	4,5	50	
4,00	6,0	50	
4,00	10,0	50	
5,00	7,5	50	
6,00	9,0	50	
7,00	10,0	50	
8,00	12,0	50	
9,00	13,5	50	
10,00	15,0	50	
11,00	16,5	50	
12,00	18,0	50	
2,00	3,0	100	
2,50	4,0	100	
3,00	4,5	100	
4,00	6,0	100	
5,00	7,5	100	
6,00	9,0	100	
7,00	10,0	100	
8,00	12,0	100	
9,00	13,5	100	
10,00	15,0	100	
11,00	16,5	100	
12,00	18,0	100	
14,00	21,0	100	
15,00	22,5	100	
16,00	24,0	100	
18,00	27,0	100	
20,00	30,0	100	
4,00	6,0	150	
5,00	7,5	150	
6,00	9,0	150	
7,00	10,0	150	
8,00	12,0	150	
9,00	13,5	150	
10,00	15,0	150	
11,00	16,5	150	
12,00	18,0	150	
14,00	21,0	150	
15,00	22,5	150	
16,00	24,0	150	
18,00	27,0	150	
20,00	30,0	150	

VHM-Unispezial-Gravierstichel mit Spitze fertiggeschliffen

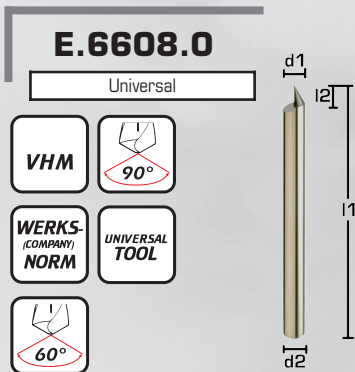

Solid carbide Unispecial steel graver with finished point

Frezy z węglika spiekanego do grawerowania stali

Bulini in MD con punta affilata

Buriles de metal duro unispecial con punta afilada

Artikel-Nr. Article-No.				E.6608.0 € Stück piece
d1	l2	l1		
2,00	3,0	50		
2,50	3,0	50		
3,00	4,5	50		
4,00	6,0	50		
5,00	7,5	50		
6,00	9,0	50		
7,00	11,5	50		
8,00	12,0	50		
2,00	3,0	100		
2,50	3,0	100		
3,00	4,5	100		
4,00	6,0	100		
5,00	7,5	100		
6,00	9,0	100		
7,00	11,5	100		
8,00	12,0	100		
9,00	13,5	100		
10,00	15,0	100		
11,00	16,5	100		
12,00	18,0	100		
14,00	21,0	100		
16,00	24,0	100		

VHM-Unispezial-Gravierfräser

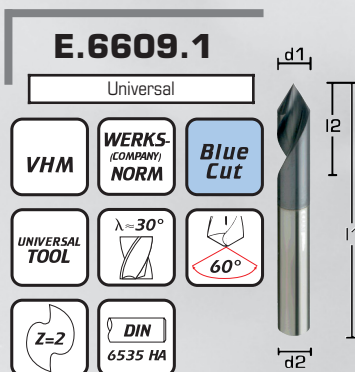

Solid carbide Unispecial engraving end mills

Frezy z węglika spiekanego dwuostrzowe do grawerowania

Frese in MD a gravare

Fresas de metal duro unispecial para grabar

Artikel-Nr. Article-No.					E.6609.1 € Stück piece
d1	l3	l2	l1	d2 h6	
3,00	2	10	40	3,0	
4,00	3	10	40	4,0	
6,00	5	10	50	6,0	

- Gewindebohrer 1
- Bohren HSSE 2
- Bohren VHM 3
- Reiben HSSE 4
- Reiben VHM 5
- Frässtifte VHM 6
- Unispezial 7
- WP-Werkzeuge 8
- Fräsen HSSE 9
- Sägen 10
- Lehren 11
- Nachschleifen 12
- Sonstiges 13

VHM-Unispezial-Plattensitz-Gesenkfräser 30°

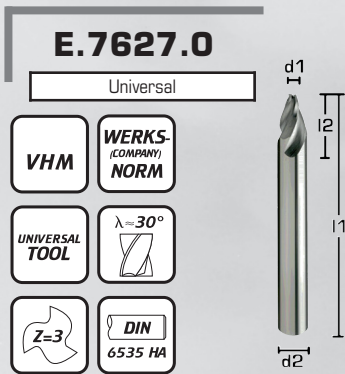

Solid carbide Unispecial milling cutters for indexable seats 30°

Frezy z węgla spiekanego trzyostrzowe 30° do frezowania gniazd pod płytki skrawające

Frese coniche in MD 30° per la lavorazione delle placchette per inserti

Fresas cónicas de metal duro unispecial para alojamientos de plaquitas de metal duro

Zur Herstellung des Plattensitzes bei Wendeplattenwerkzeugen!

For production of indexable inserts seats at inserts tools!

Artikel-Nr. Article-No.					E.7627.0 € Stück piece
Grad degree	d1	l2	l1	d2 h6	
5°	1,80	8	50	6,0	
6°	1,80	8	50	6,0	
7°	1,80	8	50	6,0	
11°	1,80	8	50	6,0	
15°	1,80	8	50	6,0	
20°	1,80	8	50	6,0	

VHM-Unispezial-Schaftfräser für HSK-Innenkontur 30°

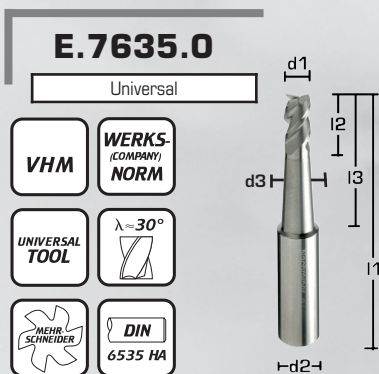

Solid carbide Unispecial end mills for HSK-internal contour 30°

Frezy z węgla spiekanego wieloostrowe 30° do konturów wewnętrznych HSK

Frese in MD 30° per scontornare interni HSK

Fresas de metal duro unispecial de 30° para contornear HSK

Artikel-Nr. Article-No.							Zähne flutes	E.7635.0 € Stück piece
für HSK for HSK	d1	d3	l2 + - 0,1	l3 + - 0,5	l1	d2 h6		
25,00	2,4	2,0	5,0	15,6	53	6,0	3	
32,00	2,9	2,4	6,0	18,0	50	6,0	3	
40,00	3,8	3,3	7,0	21,0	50	6,0	3	
50,00	4,8	4,3	9,0	29,0	60	8,0	3	
63,00	5,7	5,3	11,5	36,5	65	10,0	3	
80,00	7,7	7,2	13,0	41,0	75	12,0	3	
100,00	9,5	9,0	16,0	54,0	90	10,0	3	
125,00	11,5	10,8	21,0	66,0	115	16,0	4	
160,00	14,0	13,0	25,0	80,0	132	16,0	4	

VHM-Unispezial-Mikrogesenkfräser 25°

E.7704.0

Universal

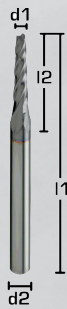
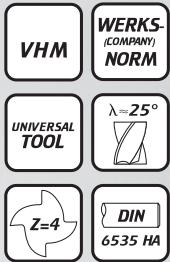

Solid carbide Unispecial micro diesinking cutters 25°

Frezy z węgla spiekane czteroostrzowe zbieżne, linia śrubowa ostrza 25°

Microfresse coniche MD universali a 25°

Microfresas cónicas de metal duro unispecial de 25°

Artikel-Nr. Article-No.					E.7704.0	Artikel-Nr. Article-No.					E.7704.0
Winkel angle	d1	l2	l1	d2 h6	Stück piece	Winkel angle	d1	l2	l1	d2 h6	Stück piece
30°	1,0	8	45	4,0		1°	1,2	8	45	4,0	
30°	1,0	12	45	4,0		1°	1,2	12	45	4,0	
1°	1,0	8	45	4,0		1° 30°	1,2	8	45	4,0	
1°	1,0	12	45	4,0		1° 30°	1,2	12	45	4,0	
1° 30°	1,0	8	45	4,0		2°	1,2	8	45	4,0	
1° 30°	1,0	12	45	4,0		2°	1,2	12	45	4,0	
2°	1,0	8	45	4,0		30°	1,5	8	45	4,0	
2°	1,0	12	45	4,0		30°	1,5	12	45	4,0	
30°	1,2	8	45	4,0		30°	1,5	16	50	4,0	
30°	1,2	12	45	4,0		1°	1,5	8	45	4,0	

VHM-Unispezial-Radiusgesenkfräser 25°

E.7705.0

Universal

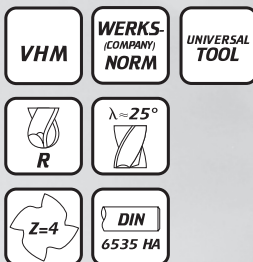

Solid carbide Unispecial diesinking ball nose cutters 25°

Frezy z węgla spiekane czteroostrzowe zbieżne z czołem kulistym, linia środkowa ostrza 25°

Frese raggiate coniche MD universali a 25°

Fresas cónicas de metal duro unispecial de 25° con radio

Artikel-Nr. Article-No.					E.7705.0	Artikel-Nr. Article-No.					E.7705.0
Winkel angle	d1	l2	l1	d2 h6	Stück piece	Winkel angle	d1	l2	l1	d2 h6	Stück piece
30°	1,0	8	45	4,0		1°	1,2	8	45	4,0	
30°	1,0	12	45	4,0		1°	1,2	12	45	4,0	
1°	1,0	8	45	4,0		1° 30°	1,2	8	45	4,0	
1°	1,0	12	45	4,0		1° 30°	1,2	12	45	4,0	
1° 30°	1,0	8	45	4,0		2°	1,2	8	45	4,0	
1° 30°	1,0	12	45	4,0		2°	1,2	12	45	4,0	
2°	1,0	8	45	4,0		30°	1,5	8	45	4,0	
2°	1,0	12	45	4,0		30°	1,5	12	45	4,0	
30°	1,2	8	45	4,0		30°	1,5	16	50	4,0	
30°	1,2	12	45	4,0		1°	1,5	8	45	4,0	

- Gewindebohrer 1
- Bohren HSSE 2
- Bohren VHM 3
- Reiben HSSE 4
- Reiben VHM 5
- Frässtifte VHM 6
- Unispezial 7
- WP-Werkzeuge 8
- Fräsen HSSE 9
- Sägen 10
- Lehren 11
- Nachtschleifen 12
- Sonstiges 13

VHM-Unispezial-Gesenkfräser konisch

E.7671.0

Universal



Solid carbide Unispecial die-milling cutters conical

Frezy z węgla spiekanego stożkowe zbieżne

Frese coniche universali MD

Fresas cónicas de metal duro unispecial

Artikel-Nr. Article-No.						E.7671.0	Artikel-Nr. Article-No.						E.7671.0
Winkel angle	d1	l2	l1	d2	Zähne flutes	€ Stück piece	Winkel angle	d1	l2	l1	d2	Zähne flutes	€ Stück piece
0,5°	3,0	20	60	4,0	4		2,00	3,0	20	60	5,0	4	
0,5°	4,0	20	60	5,0	4		2,00	3,5	20	60	5,0	4	
0,5°	5,0	30	75	6,0	6		2,00	4,0	20	65	6,0	4	
0,5°	6,0	30	75	8,0	6		2,00	4,5	30	75	8,0	4	
0,5°	8,0	30	80	10,0	6		2,00	5,0	30	75	8,0	6	
0,5°	10,0	30	85	12,0	6		2,00	6,0	28	75	8,0	6	
0,5°	12,0	30	85	14,0	6		2,00	8,0	28	75	10,0	6	
0,5°	16,0	60	120	18,0	6		2,00	10,0	28	85	12,0	6	
1,0°	3,0	20	60	4,0	4		2,00	12,0	28	85	14,0	6	
1,0°	3,5	20	60	5,0	4		2,00	16,0	55	115	20,0	6	
1,0°	4,0	20	60	5,0	4		2,50	3,0	20	60	5,0	4	
1,0°	4,5	20	65	6,0	6		2,50	4,0	20	65	6,0	4	
1,0°	5,0	25	70	6,0	6		2,50	5,0	30	75	8,0	6	
1,0°	6,0	30	75	8,0	6		2,50	6,0	30	80	10,0	6	
1,0°	8,0	30	80	10,0	6		2,50	8,0	30	85	12,0	6	
1,0°	10,0	30	85	12,0	6		2,50	10,0	40	100	14,0	6	
1,0°	12,0	30	85	14,0	6		3,00	8,0	30	75	8,0	4	
1,0°	16,0	55	115	18,0	6		3,00	8,0	30	75	8,0	6	
1,5°	3,0	20	60	4,0	4		3,00	10,0	40	90	10,0	6	
1,5°	3,5	20	60	5,0	4		3,00	10,0	30	80	10,0	6	
1,5°	4,0	20	60	5,0	4		3,00	12,0	30	85	12,0	6	
1,5°	4,5	20	65	6,0	4		3,00	14,0	30	85	14,0	6	
1,5°	5,0	30	75	6,0	6		3,00	16,0	30	90	16,0	6	
1,5°	6,0	30	75	8,0	6								
1,5°	8,0	30	75	10,0	6								
1,5°	10,0	30	85	12,0	6								
1,5°	12,0	30	85	14,0	6								
1,5°	16,0	55	125	20,0	6								

VHM-Unispezial-Gesenkfräser 30°

E.7629.0

Universal

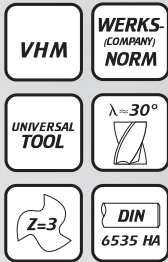

Solid carbide Unispecial diesinking cutters 30°

Frezy z węgla spiekanego trzyostrzowe zbieżne, linia środkowa ostrza 30°

Frese coniche universali MD a 30°

Fresas cónicas de metal duro unispecial de 30°

Artikel-Nr. Article-No.					E.7629.0 € Stück piece
Winkel angle	d1	l2	l1	d2 h6	
1°	4,5	20	57	6,0	
1°	6,0	30	63	8,0	
1°	8,0	30	72	10,0	
1°	10,0	35	83	12,0	
1°	12,0	35	83	14,0	
3°	4,0	30	63	8,0	
3°	6,0	30	72	10,0	
3°	8,0	35	83	12,0	
3°	10,0	35	83	14,0	
3°	12,0	55	100	18,0	
5°	3,0	25	63	8,0	
5°	3,5	30	72	10,0	
5°	4,0	35	83	12,0	
5°	8,0	35	83	14,0	
5°	9,0	40	92	16,0	

VHM-Unispezial-Gesenkfräser 30° mit Stirnradius

E.7630.0

Universal



Solid carbide Unispecial diesinking cutters 30° with face radius

Frezy z węgla spiekanego trzyostrzowe zbieżne z czołem kulistym, linia środkowa ostrza 30°

Frese coniche con raggio frontale, universali a 30°

Fresas cónicas de metal duro unispecial de 30° con radio frontal

Artikel-Nr. Article-No.						E.7630.0 € Stück piece
Winkel angle	d1	R	l2	l1	d2 h6	
1°	4,5	2,25	20	57	6,0	
1°	6,0	3,00	30	63	8,0	
1°	8,0	4,00	30	72	10,0	
1°	10,0	5,00	35	83	12,0	
1°	12,0	6,00	35	83	14,0	
3°	4,0	2,00	30	63	8,0	
3°	6,0	3,00	30	72	10,0	
3°	8,0	4,00	35	83	12,0	
3°	10,0	5,00	35	83	14,0	
3°	12,0	6,00	55	100	18,0	
5°	3,0	1,50	25	63	8,0	
5°	3,5	1,75	30	72	10,0	
5°	4,0	2,00	35	83	12,0	
5°	8,0	4,00	35	83	14,0	
5°	9,0	4,50	40	92	16,0	

- Gewindebohrer 1
- Bohren HSSE 2
- Bohren VHM 3
- Reiben HSSE 4
- Reiben VHM 5
- Frässtifte VHM 6
- Unispezial 7
- WP-Werkzeuge 8
- Fräsen HSSE 9
- Sägen 10
- Lehren 11
- Nachschleifen 12
- Sonstiges 13

VHM-Unispezial-Mikro-Viertelkreis-Konkavfräser

E.7658.0

Universal

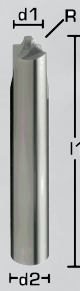

Solid carbide Unispezial micro corner rounding cutters concave

Frezy miniaturowe z węgla spiekanego dwuostrzowe wklęsłe do załamywania krawędzi

Microfresse universali MD con un quarto di raggio per fresatura concava

Microfresas cóncavas de metal duro unispezial con un cuarto de radio

Artikel-Nr. Article-No.				E.7658.0 € Stück piece
R	d1	l1	d2 h6	
0,10	1,0	50	3,0	
0,15	1,0	50	3,0	
0,20	1,0	50	3,0	
0,25	1,0	50	3,0	
0,30	1,0	50	3,0	
0,40	1,0	50	3,0	
0,50	1,5	50	3,0	
0,60	1,5	50	3,0	
0,70	1,5	50	3,0	
0,80	1,5	50	3,0	
0,90	1,5	50	3,0	
1,00	1,5	50	3,0	
1,50	2,0	50	6,0	
2,00	2,5	50	8,0	

VHM-Unispezial-Viertelkreisfräser konkav

E.7659.0

Universal



Solid carbide Unispezial corner rounding cutters concave

Frezy z węgla spiekanego czterostrzowe wklęsłe do załamywania krawędzi

Frese universali MD con un quarto di raggio, concave

Fresas cóncavas de metal duro unispezial con un cuarto de radio

Artikel-Nr. Article-No.				E.7659.0 € Stück piece
R	d1	l1	d2 h6	
0,50	7,0	70	8,0	
0,75	6,5	70	8,0	
1,00	6,0	70	8,0	
1,25	5,5	70	8,0	
1,50	7,0	75	10,0	
1,75	6,5	75	10,0	
2,00	6,0	75	10,0	
2,25	5,5	75	10,0	
2,50	7,0	75	12,0	
3,00	6,0	75	12,0	
3,50	9,0	80	16,0	
4,00	8,0	80	16,0	
4,50	7,0	80	16,0	
5,00	10,0	80	20,0	
6,00	8,0	80	20,0	

VHM-Unispezial-Vor-und Rückwärts-Viertelkreisfräser

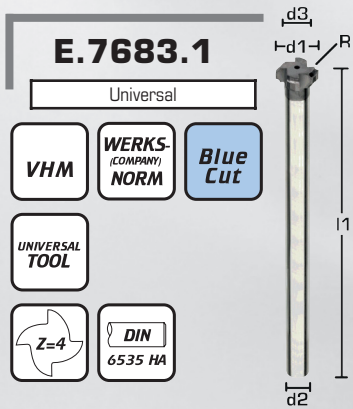

E.7683.1

Universal

VHM WERKS (COMPANY) NORM Blue Cut

UNIVERSAL TOOL

Z=4 DIN 6535 HA

Solid carbide Unispecial forward and backward quatercircle profile end mills

Frezy z węglika spiekanego profilowe ćwierć wypukło-wkłęste

Frese universali MD con un quarto di raggio per lavori bidirezionali

Fresas de metal duro unispecial con un cuarto de radio para trabajos bidireccionales

Artikel-Nr. Article-No.					E.7683.1
R	d1	d3	l1	d2	€ Stück piece
0,20	8	7,6	100	6,0	
0,30	8	7,4	100	6,0	
0,40	8	7,2	100	6,0	
0,50	8	7,0	100	6,0	
0,80	10	8,4	100	6,0	
1,00	10	8,0	100	6,0	
1,20	10	7,6	100	6,0	
1,50	10	7,0	100	6,0	

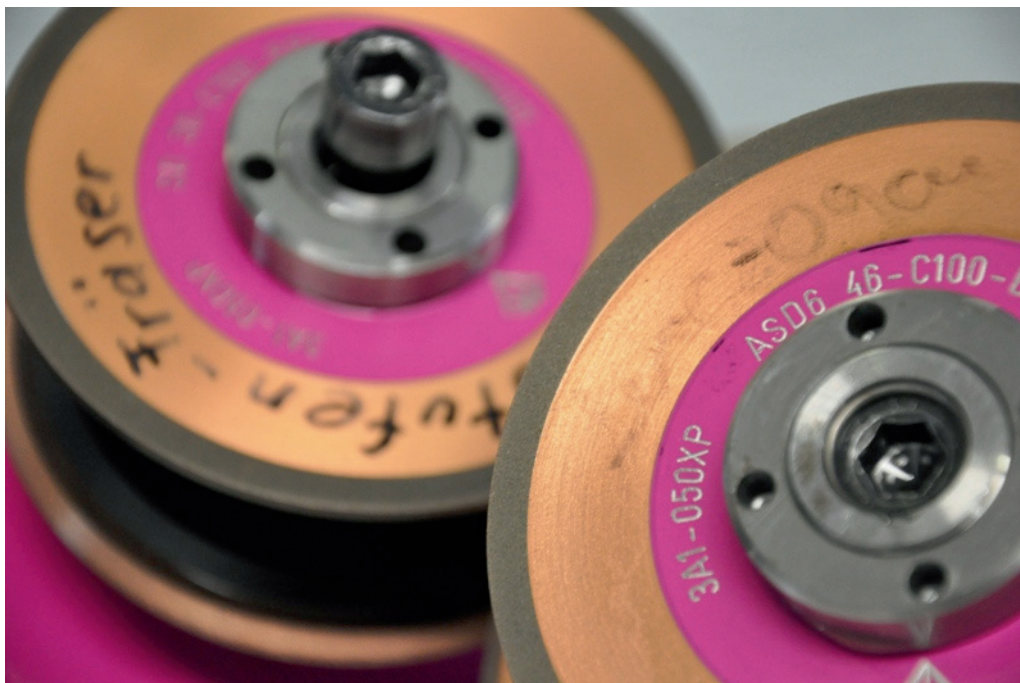

- Gewindebohrer **1**
- Bohren HSSE **2**
- Bohren VHM **3**
- Reiben HSSE **4**
- Reiben VHM **5**
- Frässtifte VHM **6**
- Unispezial **7**
- WP-Werkzeuge **8**
- Fräsen HSSE **9**
- Sägen **10**
- Lehren **11**
- Nachschleifen **12**
- Sonstiges **13**

VHM-Schrupfräser 30°

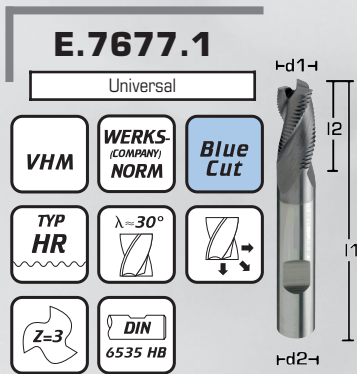

Solid carbide roughing end mills 30°

Frezy z węgla spiekanego trzyostrzowe 30° do obróbki zgrubnej

Frese universali MD con rompitrucciolo a sgrassare, 30°

Fresas de metal duro para desbaste de 30°

Artikel-Nr. Article-No.				E.7677.1 € Stück piece
d1	l2	l1	d2 h6	
3,00	6	57	6,0	
4,00	8	57	6,0	
5,00	10	57	6,0	
6,00	16	57	6,0	
8,00	16	63	8,0	
10,00	22	72	10,0	
12,00	26	83	12,0	
16,00	32	92	16,0	
20,00	38	104	20,0	

VHM-Schrupfräser 25°

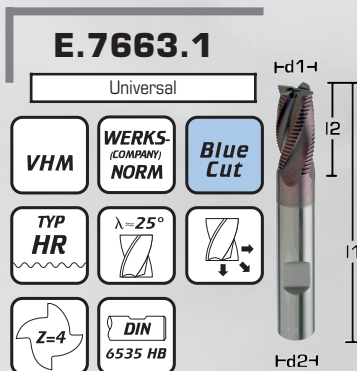

Solid carbide roughing end mills 25°

Frezy z węgla spiekanego czterostrzowe 25° do obróbki zgrubnej





Frese universali MD con rompitrucciolo a sgrassare, 25°

Fresas de metal duro para desbaste de 25°

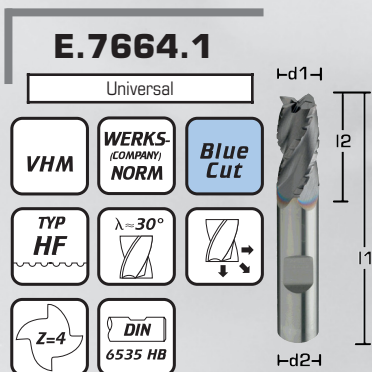
Artikel-Nr. Article-No.				E.7663.1 € Stück piece
d1	l2	l1	d2 h6	
3,00	6	57	6,0	
4,00	8	57	6,0	
5,00	10	57	6,0	
6,00	13	57	6,0	
8,00	16	63	8,0	
10,00	22	72	10,0	
12,00	26	83	12,0	
14,00	26	83	14,0	
16,00	32	92	16,0	
18,00	38	104	18,0	
20,00	38	104	20,0	
25,00	45	121	25,0	

VHM-Schruppschlichtfräser 30°





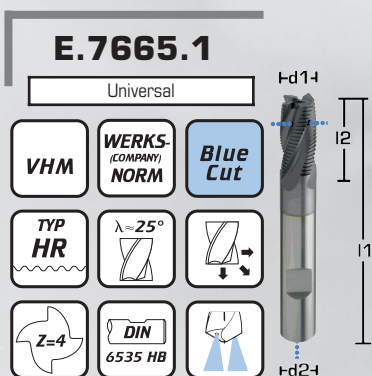

-  Solid carbide roughing finishing end mills 30°
-  Frezy z węgla spiekane go czterostrzowe 30° do obróbki zgrubno-wykańczającej
-  Frese universali MD con rompitrucciolo a sgrassar-finire, 30°
-  Fresas de metal duro de 30° para desbaste y acabado

Artikel-Nr. Article-No.				E.7664.1 € Stück piece
d1	l2	l1	d2 h6	
3,00	9	38	3,0	
3,50	11	50	4,0	
4,00	11	50	4,0	
4,50	14	50	5,0	
5,00	14	50	5,0	
6,00	14	57	6,0	
8,00	19	63	8,0	
10,00	22	66	10,0	
12,00	26	73	12,0	
14,00	26	83	14,0	
16,00	32	92	16,0	
20,00	38	104	20,0	
25,00	55	110	25,0	

VHM-Schrupfräser 25° mit Innenkühlung



-  Solid carbide roughing end mills 25° with internal coolant
-  Frezy z węgla spiekane go czterostrzowe 25° z chłodzeniem wew. do obróbki zgrubnej
-  Frese universali MD con rompitrucciolo a sgrassare, 25° con refrigerazione interna
-  Fresas de metal duro para desbaste de 25° con refrigeración interior

Artikel-Nr. Article-No.				E.7665.1 € Stück piece
d1	l2	l1	d2 h6	
6,00	13	57	6,0	
8,00	16	63	8,0	
10,00	22	72	10,0	
12,00	26	83	12,0	
16,00	32	92	16,0	
20,00	38	104	20,0	

- Gewindebohrer 1
- Bohren HSSE 2
- Bohren VHM 3
- Reiben HSSE 4
- Reiben VHM 5
- Frässtifte VHM 6
- Schruppen 7
- WP-Werkzeuge 8
- Fräsen HSSE 9
- Sägen 10
- Lehren 11
- Nachschleifen 12
- Sonstiges 13

VHM-Inox-Schruppfräser 45°

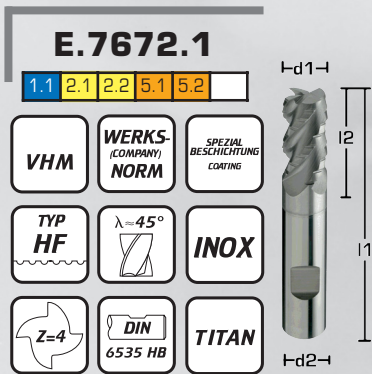

Solid carbide Inox roughing end mills 45°

Frezy z węgla spiekane go czte-roostrzowe 45° do obróbki zgrubnej stali nierdzewnej, tytanu i kobaltu

Frese con rompitrucciolo a sgrossare MD per inox, 45°

Fresas de metal duro para desbaste de 45° para inoxidable

Artikel-Nr. Article-No.				E.7672.1 € Stück piece
d1 h10	l2	l1	d2 h6	
6,00	16	57	6,0	
7,00	19	63	8,0	
8,00	19	63	8,0	
9,00	22	72	10,0	
10,00	22	72	10,0	
12,00	26	83	12,0	
16,00	32	92	16,0	
20,00	38	104	20,0	

VHM-Schruppfräser 20° extra kurz



Solid carbide roughing end mills 20° extra short

Frezy z węgla spiekane go wieloostrozowe bardzo krótkie 20° do obróbki zgrubnej

Frese con rompitrucciolo a sgrossare MD per inox, serie extra corta

Fresas de metal duro para desbaste de 20°, serie extra corta

Artikel-Nr. Article-No.					E.7633.1 € Stück piece
d1 h10	l2	l1	d2 h6	Zähne flutes	
6,00	7	54	6,0	3	
7,00	8	58	8,0	3	
8,00	9	58	8,0	3	
9,00	13	66	10,0	4	
10,00	14	66	10,0	4	
12,00	16	73	12,0	4	
14,00	18	75	14,0	4	
16,00	22	82	16,0	4	
18,00	24	84	18,0	4	
20,00	26	92	20,0	4	
25,00	25	110	25,0	5	

VHM-Primus-Schruppfräser 45° kurz

E.7678.1

Universal

VHM WERKS (COMPANY) NORM Blue Cut

TYP HR $\lambda = 45^\circ$ KURZ SHORT

MEHR-SCHNEIDER DIN 6535 HB UNIVERSAL TOOL



SET.7678.1

Universal

Vorteile_advantages:

- hohe Standzeit
long tool life
- hohe Stabilität
high stability
- schnelle Spanabfuhr
fast chip removal
- sehr stabile Schneidkanten
very stable cutting edges

- 🇬🇧 Solid carbide Primus roughing end mills 45° short
- 🇵🇱 Zestaw frezów Primus z węgliką spiekanego wieloostrowych krótkich 45° do obróbki zgrubnej
- 🇮🇹 Frese con rompitruciolo MD "Primus" a sgrossare, 45°, serie corta
- 🇪🇸 Fresas de metal duro "Primus" para desbaste de 45°, serie corta

Artikel-Nr. Article-No.						E.7678.1
d1	l2	l1	d2 h6	Zähne flutes		€ Stück piece
4,00	11	57	6,0	3		
5,00	13	57	6,0	4		
6,00	16	57	6,0	4		
7,00	16	63	8,0	4		
8,00	16	63	8,0	4		
9,00	19	72	10,0	4		
10,00	22	72	10,0	4		
12,00	26	83	12,0	4		
14,00	26	83	14,0	5		
16,00	32	92	16,0	5		
20,00	38	104	20,0	6		
25,00	45	121	25,0	6		
Satz Set						SET.7678.1
1 Stück Ø 8 / 10 / 12 / 16 mm 1 piece Ø 8 / 10 / 12 / 16 mm						

VHM-Primus-Schruppfräser 45° lang

E.7724.1

Universal

VHM WERKS (COMPANY) NORM Blue Cut

TYP HR $\lambda = 45^\circ$ LANG LONG

MEHR-SCHNEIDER DIN 6535 HA UNIVERSAL TOOL



- 🇬🇧 Solid carbide Primus roughing end mills 45° long
- 🇵🇱 Frezy wieloostrowe Primus z węgliką spiekanego 45° długie do obróbki zgrubnej
- 🇮🇹 Frese con rompitruciolo a sgrossare MD "Primus", 45°, serie lunga
- 🇪🇸 Fresas de metal duro "Primus" para desbaste de 45°, serie larga

Artikel-Nr. Article-No.						E.7724.1
d1	l2	l3	l1	d2 h6	Zähne flutes	€ Stück piece
6,00	16	20	57	6,0	4	
8,00	16	26	63	8,0	4	
10,00	22	31	72	10,0	4	
12,00	26	37	83	12,0	4	
16,00	32	51	100	16,0	5	
20,00	38	59	110	20,0	6	

- 1 Gewindbohrer
- 2 Bohren HSSE
- 3 Bohren VHM
- 4 Reiben HSSE
- 5 Reiben VHM
- 6 Frässtifte VHM
- 7 Schruppen
- 8 WP-Werkzeuge
- 9 Fräsen HSSE
- 10 Sägen
- 11 Lehren
- 12 Nachschleifen
- 13 Sonstiges

VHM-Schrupfräser 45° extra lang

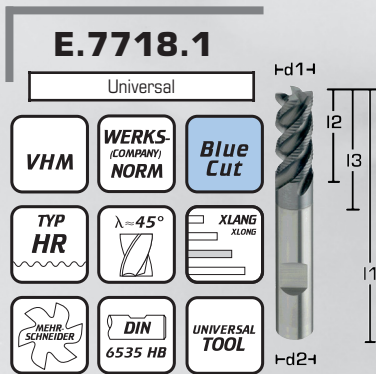

Solid carbide roughing end mills 45° extra long

Frezy z węgla spiekanego wieloostrowe bardzo długie 45° do obróbki zgrubnej

Frese con rompitruciolo a sgrossare MD, 45°, serie extra lunga

Fresas de metal duro para desbaste de 45°, serie extra larga

Artikel-Nr. Article-No.						E.7718.1 € Stück piece
d1	l2	l3	l1	d2 h6	Zähne flutes	
6,00	12	16	57	6,0	5	
8,00	16	24	63	8,0	5	
10,00	20	30	72	10,0	5	
12,00	24	36	83	12,0	5	
16,00	32	48	100	16,0	5	
20,00	40	60	110	20,0	7	

VHM-HRC-Schrupfräser 30°

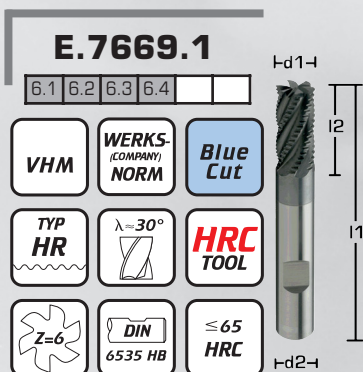

Solid carbide HRC roughing end mills 30°

Frezy z węgla spiekanego sześciostrowe do obróbki zgrubnej materiałów utwardzonych do 65 HRC

Frese MD HRC con rompitruciolo a sgrossare 30°

Fresas de metal duro para desbaste de 30° HRC

Artikel-Nr. Article-No.				E.7669.1 € Stück piece
d1	l2	l1	d2 h6	
6,00	13	57	6,0	
8,00	19	63	8,0	
10,00	22	72	10,0	
12,00	26	83	12,0	
16,00	32	92	16,0	
20,00	38	104	20,0	

VHM-Radius-Schruppfräser 30°



Solid carbide ball nose roughing end mills 30°

Frezy z węgla spiekane go wielostr-zowe 30° z czolem kulistym do obróbki zgrubnej

Frese raggiate con rompitruciolo MD a sgrossare 30°

Fresas de metal duro para desbaste de 30° con radio

Artikel-Nr. Article-No.						E.7679.1 € Stück piece
d1	R	l2	l1	d2 h6	Zähne flutes	
5,00	2,5	10	57	6,0	3	
6,00	3,0	13	57	6,0	3	
8,00	4,0	19	63	8,0	3	
10,00	5,0	22	72	10,0	4	
12,00	6,0	26	83	12,0	4	
14,00	7,0	26	83	14,0	4	
16,00	8,0	32	92	16,0	4	
18,00	9,0	32	92	18,0	4	
20,00	10,0	38	104	20,0	4	



- 1 Gewindebohrer
- 2 Bohren HSSE
- 3 Bohren VHM
- 4 Reiben HSSE
- 5 Reiben VHM
- 6 Frässtifte VHM
- 7 Schruppen
- 8 WP-Werkzeuge
- 9 Fräsen HSSE
- 10 Sägen
- 11 Lehren
- 12 Nachschleifen
- 13 Sonstiges

VHM-Alu-Einzahnfräser kurz rechts/rechts

E.6602.0

4.1 4.7

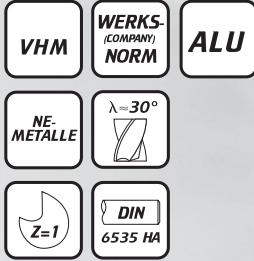

- Solid carbide Alu 1-flute end mills
- Frezy z węgla spiekane jednostrzowe do aluminium
- Frese monoelica MD per Alu
- Fresas de metal duro de un diente para aluminio

Artikel-Nr. Article-No.				E.6602.0 € Stück piece
d1	l2	l1	d2 h6	
0,50	2,5	35	3,0	
0,80	3,0	35	3,0	
1,00	4,5	35	3,0	
1,50	6,0	50	3,0	
2,00	10,0	40	2,0	
2,50	6,5	35	3,0	
3,00	10,0	40	3,0	
4,00	10,0	40	4,0	
4,00	14,0	50	4,0	
5,00	16,0	60	5,0	
6,00	14,0	50	6,0	
6,00	20,0	60	6,0	
8,00	25,0	75	8,0	
10,00	25,0	75	10,0	
12,00	25,0	75	12,0	
14,00	25,0	75	14,0	
16,00	25,0	82	16,0	
18,00	25,0	87	18,0	
20,00	30,0	92	20,0	

VHM-Alu-Einzahnfräser mit verstärktem Schaft rechts/rechts

E.6611.0

4.1 4.7

VHM WERKS- (COMPANY) NORM ALU

NE-METALLE $\lambda=30^\circ$

Z=1 DIN 6535 HA



- Solid carbide Alu 1-flute end mills with reinforced shank RH/RH
- Frezy z węglika spiekaneego jednoostrzowe ze wzmocnionym chwytym do aluminium
- Frese monoelica MD per Alu, gambo rinforzato
- Fresas de metal duro de un diente para aluminio con mango reforzado derecho/derecho

Artikel-Nr. Article-No.				E.6611.0 € Stück piece
d1	l2	l1	d2 h6	
1,50	5	40	6,0	
2,00	6	40	6,0	
2,50	8	40	6,0	
3,00	10	40	6,0	
3,50	10	40	6,0	
4,00	12	40	6,0	
4,50	12	40	6,0	
5,00	14	40	6,0	
5,50	14	40	6,0	
6,00	14	40	6,0	

VHM-Alu-Einzahnfräser Linksspirale, rechtsschneidend

E.7684.0

4.1 4.7

VHM WERKS- (COMPANY) NORM POLIERT polished

NE-METALLE $\lambda=30^\circ$ ALU

Z=1 DIN 6535 HA



- Solid carbide Alu 1-flute end mills
- Frezy z węglika spiekaneego jednoostrzowe do aluminium
- Frese monoelica MD per Alu
- Fresas de metal duro de un diente para aluminio

Artikel-Nr. Article-No.				E.7684.0 € Stück piece
d1 h10	l2	l1	d2 h6	
2,00	10	40	2,0	
3,00	12	40	3,0	
4,00	15	40	4,0	
5,00	16	50	5,0	
6,00	20	60	6,0	
8,00	22	63	8,0	
10,00	25	72	10,0	
12,00	30	83	12,0	
16,00	35	92	16,0	
20,00	40	104	20,0	

- Gewindebohrer 1
- Bohren HSSE 2
- Bohren VHM 3
- Reiben HSSE 4
- Reiben VHM 5
- Frässtifte VHM 6
- Alu 7
- WP-Werkzeuge 8
- Fräsen HSSE 9
- Sägen 10
- Lehren 11
- Nachschleifen 12
- Sonstiges 13

VHM-Alu-Mikroschaftfräser 30° mit Eckenradius

E.7694.0

4.1 4.2 4.3

VHM WERKS (COMPANY) NORM POLIERT polished

ER $\lambda=30^\circ$ HSC TOOL

Z=2 DIN 6535 HA ALU

E.7695.1

4.4 4.5 4.6

VHM WERKS (COMPANY) NORM SPEZIAL BESCHICHTUNG COATING

ER $\lambda=30^\circ$ HSC TOOL

Z=2 DIN 6535 HA KUPFER

Solid carbide Alu micro end mills 30° with corner radius

Frezy miniaturowe węglika spiekane-go dwuostrzowe 30° z promieniem na czole do aluminium

Microfresa MD con raggio d'angolo per Alu 30°

Microfresas de metal duro de 30° para aluminio con radio lateral

Artikel-Nr. Article-No.						E.7694.0	E.7695.1
d1 e8	ER	I2	I3	I1	d2 h6	€ Stück piece	€ Stück piece
0,40	0,05	0,5	2	55	3,0		
0,40	0,05	0,5	4	55	3,0		
0,50	0,05	0,6	3	55	3,0		
0,50	0,05	0,6	5	55	3,0		
0,60	0,06	0,8	2	55	4,0		
0,60	0,06	0,8	4	55	4,0		
0,60	0,06	0,8	6	55	4,0		
0,80	0,08	1,0	4	55	4,0		
0,80	0,08	1,0	6	55	4,0		
0,80	0,08	1,0	8	55	4,0		
0,80	0,08	1,0	10	55	4,0		
1,00	0,10	1,2	5	55	4,0		
1,00	0,10	1,2	10	55	4,0		
1,00	0,10	1,2	15	55	4,0		
1,00	0,10	1,2	20	55	4,0		
1,00	0,10	1,2	25	60	4,0		
1,20	0,12	1,4	6	55	4,0		
1,20	0,12	1,4	12	55	4,0		
1,20	0,12	1,4	18	55	4,0		
1,20	0,12	1,4	25	60	4,0		
1,50	0,15	1,8	4	55	4,0		
1,50	0,15	1,8	8	55	4,0		
1,50	0,15	1,8	12	55	4,0		
1,50	0,15	1,8	16	55	4,0		
1,50	0,15	1,8	20	55	4,0		
1,50	0,15	1,8	25	60	4,0		
2,00	0,20	2,0	5	65	4,0		
2,00	0,20	2,0	10	65	4,0		
2,00	0,20	2,0	15	65	4,0		
2,00	0,20	2,0	20	75	4,0		
2,00	0,20	2,0	25	75	4,0		
2,00	0,20	2,0	30	75	4,0		
3,00	0,30	3,0	5	65	4,0		
3,00	0,30	3,0	10	65	4,0		
3,00	0,30	3,0	15	65	4,0		
3,00	0,30	3,0	20	75	4,0		
3,00	0,30	3,0	25	75	4,0		
3,00	0,30	3,0	30	75	4,0		
4,00	0,30	4,0	10	65	6,0		
4,00	0,30	4,0	15	65	6,0		
4,00	0,30	4,0	20	65	6,0		
4,00	0,30	4,0	25	75	6,0		
4,00	0,30	4,0	30	75	6,0		
5,00	0,30	5,0	10	65	6,0		
5,00	0,30	5,0	20	65	6,0		
5,00	0,30	5,0	30	75	6,0		
5,00	0,30	5,0	40	90	6,0		
6,00	0,30	6,0	10	65	6,0		
6,00	0,30	6,0	20	65	6,0		
6,00	0,30	6,0	30	75	6,0		
6,00	0,30	6,0	40	90	6,0		

VHM-Alu-Mikroradiusfräser 30°

E.7690.0

4.1 4.2 4.3

VHM WERKS (COMPANY) NORM POLIERT polished

R $\lambda=30^\circ$ HSC TOOL

Z=2 DIN 6535 HA ALU

E.7691.1

4.4 4.5 4.6

VHM WERKS (COMPANY) NORM SPEZIAL BESCHICHTUNG COATING

R $\lambda=30^\circ$ HSC TOOL

Z=2 DIN 6535 HA KUPFER

Solid carbide Alu micro ball nose end mills 30°

Frezy miniaturowe z węglika spiekanego dwuostrzowe 30° z czotem kulistym do aluminium

Microfresse raggiate MD per Alu, 30°

Microfresas de metal duro de 30° para aluminio con radio

Artikel-Nr. Article-No.						E.7690.0	E.7691.1
d1	R	l2	l3	l1	d2	€ Stück piece	€ Stück piece
0,40	0,20	0,5	2	55	3,0		
0,40	0,20	0,5	4	55	3,0		
0,50	0,25	0,6	3	55	3,0		
0,50	0,25	0,6	5	55	3,0		
0,60	0,30	0,8	2	55	4,0		
0,60	0,30	0,8	4	55	4,0		
0,60	0,30	0,8	6	55	4,0		
0,80	0,40	1,0	4	55	4,0		
0,80	0,40	1,0	6	55	4,0		
0,80	0,40	1,0	8	55	4,0		
0,80	0,40	1,0	10	55	4,0		
1,00	0,50	1,2	5	55	4,0		
1,00	0,50	1,2	10	55	4,0		
1,00	0,50	1,2	15	55	4,0		
1,00	0,50	1,2	20	55	4,0		
1,00	0,50	1,2	25	60	4,0		
1,20	0,60	1,4	6	55	4,0		
1,20	0,60	1,4	12	55	4,0		
1,20	0,60	1,4	18	55	4,0		
1,20	0,60	1,4	25	60	4,0		
1,50	0,75	1,8	4	55	4,0		
1,50	0,75	1,8	8	55	4,0		
1,50	0,75	1,8	12	55	4,0		
1,50	0,75	1,8	16	55	4,0		
1,50	0,75	1,8	20	55	4,0		
1,50	0,75	1,8	25	60	4,0		
2,00	1,00	2,0	5	65	4,0		
2,00	1,00	2,0	10	65	4,0		
2,00	1,00	2,0	15	65	4,0		
2,00	1,00	2,0	20	75	4,0		
2,00	1,00	2,0	25	75	4,0		
2,00	1,00	2,0	30	75	4,0		
3,00	1,50	3,0	5	65	4,0		
3,00	1,50	3,0	10	65	4,0		
3,00	1,50	3,0	15	65	4,0		
3,00	1,50	3,0	20	75	4,0		
3,00	1,50	3,0	25	75	4,0		
3,00	1,50	3,0	30	75	4,0		
4,00	2,00	4,0	10	65	6,0		
4,00	2,00	4,0	15	65	6,0		
4,00	2,00	4,0	20	65	6,0		
4,00	2,00	4,0	25	75	6,0		
4,00	2,00	4,0	30	75	6,0		
5,00	2,50	5,0	10	65	6,0		
5,00	2,50	5,0	20	65	6,0		
5,00	2,50	5,0	30	75	6,0		
5,00	2,50	5,0	40	90	6,0		
6,00	3,00	6,0	10	65	6,0		
6,00	3,00	6,0	20	65	6,0		
6,00	3,00	6,0	30	75	6,0		
6,00	3,00	6,0	40	90	6,0		

- 1 Gewindebohrer
- 2 Bohren HSSE
- 3 Bohren VHM
- 4 Reiben HSSE
- 5 Reiben VHM
- 6 Frässtifte VHM
- 7 Alu
- 8 WP-Werkzeuge
- 9 Fräsen HSSE
- 10 Sägen
- 11 Lehren
- 12 Nachschleifen
- 13 Sonstiges

VHM-Alu-Schaftfräser gerade genutet kurz

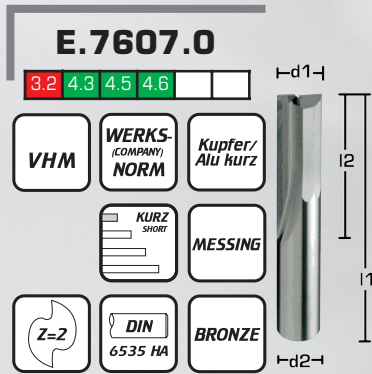

Solid carbide Alu end mills straight fluted short

Frezy z węgla spiekanego dwuostrzowe krókie o ostrzach prostych do aluminium





Frese MD per Alu, denti dritti

Fresas de metal duro de 30° para aluminio, labios rectos, serie corta

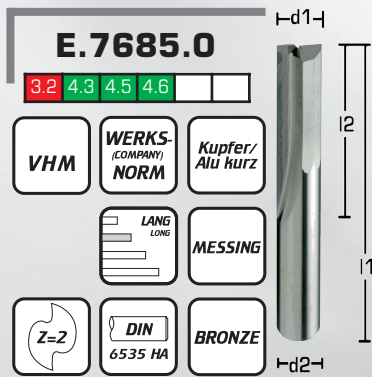
Artikel-Nr. Article-No.				E.7607.0 € Stück piece
d1 h7	l2	l1	d2 h6	
2,00	8	38	2,0	
2,50	8	38	2,5	
3,00	12	38	3,0	
3,50	12	40	3,5	
4,00	12	40	4,0	
4,50	14	50	4,5	
5,00	14	50	5,0	
5,50	16	50	5,5	
6,00	16	50	6,0	
6,50	16	50	6,5	
7,00	20	60	7,0	
7,50	20	60	7,5	
8,00	20	60	8,0	
8,50	20	60	8,5	
9,00	20	60	9,0	
9,50	22	70	9,5	
10,00	22	70	10,0	
11,00	22	70	11,0	
12,00	22	70	12,0	
13,00	25	75	13,0	
14,00	25	75	14,0	
15,00	25	75	15,0	
16,00	25	75	16,0	
18,00	32	100	18,0	
20,00	32	100	20,0	

VHM-Alu-Schaftfräser gerade genutet lang





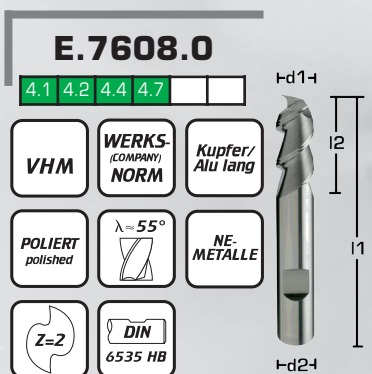

-  Solid carbide Alu end mills straight fluted long
-  Frezy z węgla spiekane go dwuostrzowe długie o ostrzach prostych do aluminium
-  Frese MD per Alu, denti dritti, serie lunga
-  Fresas de metal duro para aluminio, labios rectos, serie larga

Artikel-Nr. Article-No.				E.7685.0 € Stück piece
d1 h10	l2	l1	d2 h6	
3,00	12	40	3,0	
4,00	14	40	4,0	
5,00	16	50	5,0	
6,00	18	50	6,0	
8,00	20	63	8,0	
10,00	25	72	10,0	
12,00	30	83	12,0	
16,00	35	92	16,0	
20,00	45	104	20,0	

VHM-Alu-Universalfräser 55°



-  Solid carbide Alu universal end mills 55°
-  Frezy z węgla spiekane go uniwersalne dwuostrzowe 55° do aluminium
-  Frese MD universali per Alu, 55°
-  Fresas de metal duro para aluminio de 55° para uso universal

Artikel-Nr. Article-No.				E.7608.0 € Stück piece
d1	l2	l1	d2 h6	
3,00	8	57	6,0	
4,00	11	57	6,0	
5,00	13	57	6,0	
6,00	13	57	6,0	
8,00	19	63	8,0	
10,00	22	72	10,0	
12,00	26	83	12,0	
14,00	26	83	14,0	
16,00	32	92	16,0	
18,00	32	92	18,0	
20,00	38	104	20,0	

- Gewindebohrer 1
- Bohren HSSE 2
- Bohren VHM 3
- Reiben HSSE 4
- Reiben VHM 5
- Frässtifte VHM 6
- Alu 7
- WP-Werkzeuge 8
- Fräsen HSSE 9
- Sägen 10
- Lehren 11
- Nachschleifen 12
- Sonstiges 13

VHM-Alu-Schaftfräser 25°

E.7617.0

4.2 4.3 4.5 4.7



Solid carbide Alu end mills 25°

Frezy z węgla spiekanego dwuostrzowe 25° do aluminium

Frese in MD ALU 25°

Fresas de metal duro para aluminio de 25°

Artikel-Nr. Article-No.

d1	l2	l1	d2 h6	E.7617.0 € Stück piece
2,00	10	38	2,0	
3,00	12	38	3,0	
4,00	12	40	4,0	
5,00	12	50	5,0	
6,00	18	60	6,0	
7,00	18	60	7,0	
8,00	18	60	8,0	
9,00	22	70	9,0	
10,00	22	70	10,0	
12,00	22	70	12,0	
14,00	25	80	14,0	
16,00	25	80	16,0	
18,00	30	100	18,0	
20,00	35	100	20,0	

VHM-Alu-Kugelfräser 40°

E.7621.1

4.1 4.2 4.3 4.4 4.5 4.6

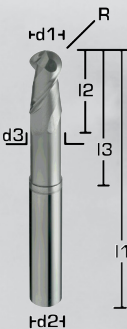

Solid carbide Alu ball nose end mills 40°

Frezy z węgla spiekanego dwuostrzowe 40° z czółem kulistym do aluminium

Frese raggriate MD, 40°

Fresas de metal duro para aluminio de 40° con punta bola

Kugel bis 220° einsetzbar
Ball useable up to 220°

Artikel-Nr. Article-No.

d1	R	d3	l2	l3	l1	d2 h6	E.7621.1 € Stück piece
1,00	0,5	0,9	2	15	60	6,0	
2,00	1,0	1,8	4	20	60	6,0	
3,00	1,5	2,8	6	25	70	6,0	
4,00	2,0	3,7	8	25	70	6,0	
5,00	2,5	4,6	10	25	70	6,0	
6,00	3,0	5,5	12	35	80	6,0	
8,00	4,0	7,4	16	35	80	8,0	
10,00	5,0	9,2	20	45	90	10,0	
12,00	6,0	11,0	24	50	100	12,0	

VHM-Alu-Power-Schaftfräser 45°

E.7636.0

4.1 4.2 4.3 4.4 4.5 4.6



Solid carbide Alu Power end mills 45°

Frezy Power z węgla spiekane go trzostrzowe 45° do aluminium

Frese MD Alu-Power 45°

Fresas de metal duro "Power" para aluminio de 45°

Artikel-Nr. Article-No.

E.7636.0

€
Stück piece

d1	l2	l1	d2 h6	E.7636.0 € Stück piece
6,00	16	60	6,0	
8,00	25	78	8,0	
10,00	28	78	10,0	
12,00	32	89	12,0	
14,00	32	89	14,0	
16,00	36	96	16,0	
20,00	45	111	20,0	
25,00	50	126	25,0	

VHM-Alu-Power-Schrupfräser 45° mit Eckenradius

E.7637.0

4.3 4.5 4.6



Solid carbide Alu Power roughing end mills 45° with corner radius

Frezy Power z węgla spiekane go trzostrzowe 45° z promieniem na czole do obróbki zgrubnej

Frese con rompitrucciolo MD e raggio d'angolo per Alu-Power 45°

Fresas de metal duro "Power" de desbaste para aluminio de 45° con radio lateral

Zum Bohren geeignet
Suitable for drilling

Artikel-Nr. Article-No.

E.7637.0

€
Stück piece

d1	ER	l2	l1	d2 h6	E.7637.0 € Stück piece
6,00	0,4	16	60	6,0	
8,00	0,5	25	78	8,0	
10,00	0,6	28	78	10,0	
12,00	0,8	32	89	12,0	
14,00	1,0	32	89	14,0	
16,00	1,0	36	96	16,0	
20,00	1,2	45	111	20,0	
25,00	1,5	50	126	25,0	

Gewindebohrer 1

Bohren HSSE 2

Bohren VHM 3

Reiben HSSE 4

Reiben VHM 5

Frässtifte VHM 6

Alu 7

WP-Werkzeuge 8

Fräsen HSSE 9

Sägen 10

Lehren 11

Nachschleifen 12

Sonstiges 13

VHM-Alu-Schaftfräser 45° mit Innenkühlung

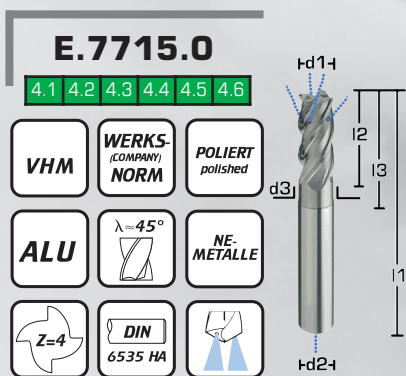

Solid carbide Alu end mills 45° with internal coolant

Frezy z węgla spiekanego czteroostrowe 45° z chłodzeniem wewnętrznym do aluminium

Frese MD per Alu 45° con refrigerazione interna

Fresas de metal duro para aluminio de 45° con refrigeración interior

Artikel-Nr. Article-No.							E.7715.0 € Stück piece
d1	d3	l2	l3	l1	d2 h6		
3,00	2,8	11	18	57	6,0		
4,00	3,6	12	21	57	6,0		
5,00	4,5	15	21	57	6,0		
6,00	5,5	15	21	57	6,0		
8,00	7,5	21	28	63	8,0		
10,00	9,5	22	32	72	10,0		
12,00	11,5	28	38	83	12,0		
14,00	13,5	30	42	83	14,0		
16,00	15,5	35	45	92	16,0		
20,00	19,5	41	55	104	20,0		
25,00	24,0	51	65	110	25,0		

VHM-Alu-Schaftfräser 40°

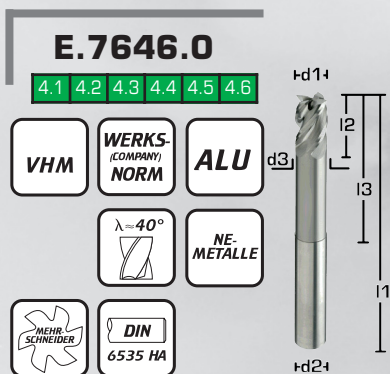

Solid carbide Alu end mills 40°

Frezy z węgla spiekanego wieloostrowe 40° do aluminium

Frese in MD ALU 40°

Fresas de metal duro para aluminio de 40°

Artikel-Nr. Article-No.							E.7646.0 € Stück piece
d1	d3	l2	l3	l1	d2 h6	Zähne flutes	
6,00	5,7	12	30	70	6,0	3	
8,00	7,7	14	35	80	8,0	3	
10,00	9,7	16	45	90	10,0	3	
12,00	11,5	18	55	100	12,0	4	
16,00	15,5	20	65	115	16,0	4	
20,00	19,5	22	75	125	20,0	4	

VHM-Alu-Schaftfräser 20°

E.7727.0

4.1 4.2 4.3 4.4 4.5 4.7



Solid carbide Alu end mills 20°

Frezy z węgla spiekanego wielostrzowe 20° do aluminium

Frese in MD ALU 20°

Fresas de metal duro para aluminio de 20°

Artikel-Nr. Article-No.						E.7727.0 € Stück piece
d1	l2	l3	l1	d2	Zähne flutes	
4,00	13	16	54	4,0	2	
5,00	15	18	54	5,0	2	
6,00	16	21	64	6,0	2	
8,00	22	27	70	8,0	2	
10,00	22	32	72	10,0	2	
12,00	28	38	83	12,0	3	
14,00	30	42	83	14,0	3	
16,00	36	44	92	16,0	3	
18,00	36	50	92	18,0	3	
20,00	41	54	104	20,0	4	
25,00	43	63	110	25,0	4	

VHM-Alu-Konturenfräser mit Diamantverzahnung

E.7755.0

4.2 4.5 4.7 4.8

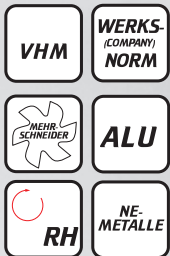

Solid carbide Alu end mill with diamond teeth

Frezy z węgla spiekanego wielostrzowe z ostrzami diamentowymi do aluminium

Frese MD per scontornare Alu con denti diamantati





Fresas de metal duro para aluminio para contornear con dientes diamantados

Artikel-Nr. Article-No.				E.7755.0 € Stück piece	Artikel-Nr. Article-No.				E.7755.0 € Stück piece
d1	l2	l1	d2		d1	l2	l1	d2	
0,80	4,0	38	3,0		2,00	8,5	38	3,0	
0,90	4,0	38	3,0		2,10	8,5	38	3,0	
1,00	4,5	38	3,0		2,20	8,5	38	3,0	
1,10	4,5	38	3,0	Auf Anfrage	2,30	8,5	38	3,0	Auf Anfrage
1,20	4,5	38	3,0		2,40	8,5	38	3,0	
1,30	4,5	38	3,0		2,50	8,5	38	3,0	
1,40	4,5	38	3,0	on demand	2,60	8,5	38	3,0	on demand
1,50	6,5	38	3,0		2,70	8,5	38	3,0	
1,60	6,5	38	3,0		2,80	8,5	38	3,0	
1,70	6,5	38	3,0		2,90	8,5	38	3,0	
1,80	6,5	38	3,0		3,00	9,5	38	3,0	
1,90	6,5	38	3,0		3,175	9,5	38	3,0	

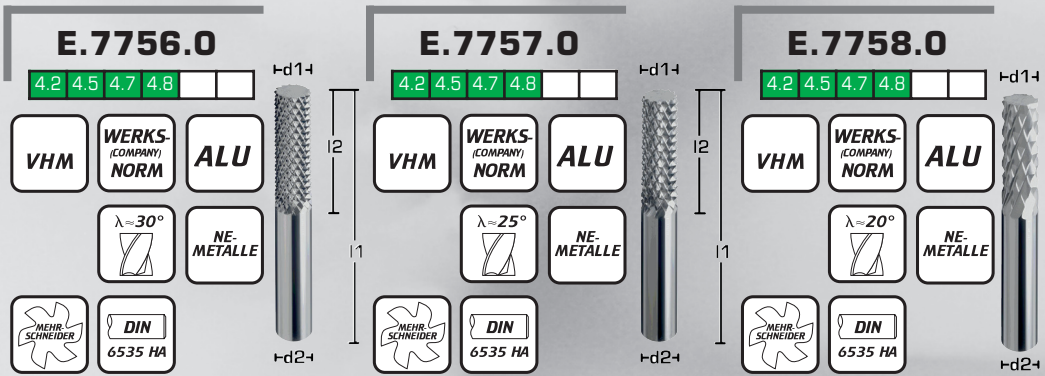
- Gewindebohrer 1
- Bohren HSSE 2
- Bohren VHM 3
- Reiben HSSE 4
- Reiben VHM 5
- Frässtifte VHM 6
- Alu 7
- WP-Werkzeuge 8
- Fräsen HSSE 9
- Sägen 10
- Lehren 11
- Nachschleifen 12
- Sonstiges 13

VHM-Alu-Schaftfräser kreuzverzahnt





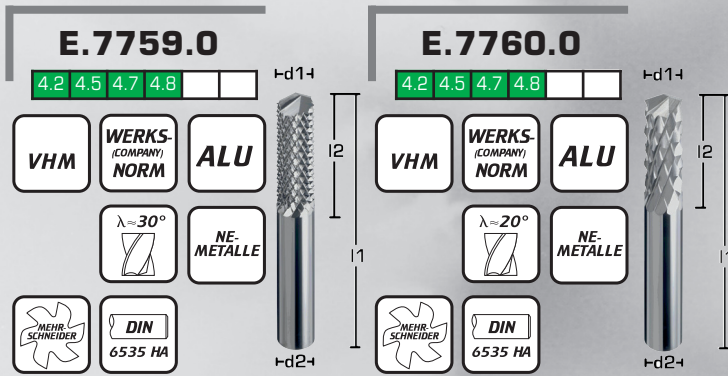

-  Solid carbide Alu end mills cross cut
-  Frezy z węgla spiekanego naprzemiennie skośne wielostrzowe do aluminium
-  Frese MD per Alu denti incrociati
-  Fresas de metal duro para aluminio con diente cruzado

Artikel-Nr. Article-No.				E.7756.0	E.7757.0	E.7758.0
d1 h10	l2	l1	d2 h6	€ Stück piece	€ Stück piece	€ Stück piece
2,00	7	40	2,0			
2,00	7	50	6,0			
3,00	10	40	3,0			
3,00	12	50	6,0			
4,00	15	40	4,0			
4,00	20	50	6,0			
5,00	16	50	5,0			
5,00	25	75	6,0			
6,00	18	50	6,0			
6,00	35	75	6,0			
8,00	25	63	8,0			
8,00	40	100	8,0			
10,00	30	72	10,0			
12,00	32	83	12,0			
16,00	36	92	16,0			
20,00	45	104	20,0			

VHM-Alu-Bohrfräser kreuzverzahnt



-  Solid carbide Aludrill milling cutter cross cut
-  Frezo-wiertła z węgla spiekane go naprzemiennie skośne wielostrzowe do do aluminium
-  Frese-punte MD per Alu denti incrociati
-  Fresas-brocas de metal duro para aluminio con diente cruzado

Artikel-Nr. Article-No.				E.7759.0	E.7760.0
d1 h10	l2	l1	d2 h6	€ Stück piece	€ Stück piece
2,00	7	40	2,0		
2,00	7	50	6,0		
3,00	10	40	3,0		
3,00	12	50	6,0		
4,00	15	40	4,0		
4,00	20	50	6,0		
5,00	16	50	5,0		
5,00	25	75	6,0		
6,00	18	50	6,0		
6,00	35	75	6,0		
8,00	25	63	8,0		
8,00	40	100	8,0		
10,00	30	72	10,0		
12,00	32	83	12,0		
16,00	36	92	16,0		
20,00	45	104	20,0		

- Gewindbohrer **1**
- Bohren HSSE **2**
- Bohren VHM **3**
- Reiben HSSE **4**
- Reiben VHM **5**
- Frässtifte VHM **6**
- Alu **7**
- WP-Werkzeuge **8**
- Fräsen HSSE **9**
- Sägen **10**
- Lehren **11**
- Nachschleifen **12**
- Sonstiges **13**

VHM-Alu-Radiusfräser kreuzverzahnt

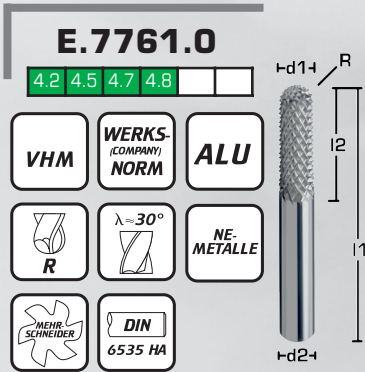

Solid carbide Alu ball nose end mills cross cut

Frezy z węgla spiekanego naprzemiennie skośne wielostrzowe z czołem kulistym do aluminium

Frese raggiate MD per Alu, denti incrociati

Fresas de radio de metal duro para aluminio con diente cruzado

Artikel-Nr. Article-No.					E.7761.0 € Stück piece
d1	R	l2	l1	d2 h6	
2,00	1,00	7	40	2,0	
2,00	1,00	7	50	6,0	
3,00	1,50	10	40	3,0	
3,00	1,50	12	50	6,0	
4,00	2,00	15	40	4,0	
4,00	2,00	20	50	6,0	
5,00	2,50	16	50	5,0	
5,00	2,50	25	75	6,0	
6,00	3,00	18	50	6,0	
6,00	3,00	35	75	6,0	
8,00	4,00	25	63	8,0	
8,00	4,00	40	100	8,0	
10,00	5,00	30	72	10,0	
12,00	6,00	32	83	12,0	
16,00	8,00	36	92	16,0	
20,00	10,00	45	104	20,0	

VHM-Alu-Bohrfräser mit gegenläufiger Spitzverzahnung

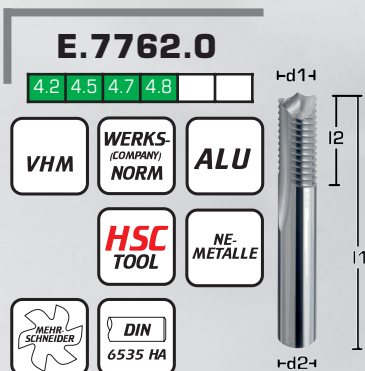

Solid carbide Alu milling cutters with counterwise point cut

Frezo-wiertła wielostrzowe z węgla spiekanego do aluminium

Frese-punte MD per Alu, denti affilati al contrario

Fresas-brocas de metal duro para aluminio con diente afilado en contracorriente

Artikel-Nr. Article-No.				E.7762.0 € Stück piece
d1	l2	l1	d2 h6	
3,00	12	50	3,0	
4,00	14	50	4,0	
5,00	16	50	5,0	
6,00	20	60	6,0	
8,00	22	63	8,0	
10,00	25	72	10,0	
12,00	30	83	12,0	
16,00	35	92	16,0	
20,00	45	104	20,0	

VHM-Alu-Schaftfräser mit großen Spannuten

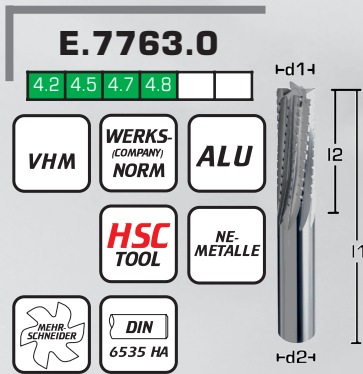

Solid carbide Alu end mills with large chip flutes

Frezy z węglika spiekanego wielostrzowe do obróbki zgrubnej aluminium

Frese MD per Alu con scanalature profonde

Fresas de metal duro para aluminio con ranuras grandes

Artikel-Nr. Article-No.				E.7763.0 € Stück piece
d1	l2	l1	d2 h6	
2,00	6	40	6,0	
3,00	12	40	3,0	
3,00	12	50	6,0	
4,00	14	40	6,0	
5,00	16	50	5,0	
6,00	18	50	6,0	
8,00	20	63	8,0	
10,00	25	72	10,0	
12,00	30	83	12,0	

VHM-Alu-Hochgeschwindigkeitsfräser

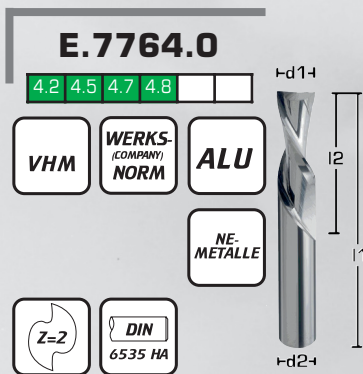

Solid carbide Alu high speed end mills

Frezy z węglika spiekanego dwustrzowe do obróbki szybkościowej do aluminium

Frese MD alte prestazioni per Alu

Fresas de metal duro para aluminio para alta velocidad

Artikel-Nr. Article-No.				E.7764.0 € Stück piece
d1 h10	l2	l1	d2 h6	
3,00	12	40	3,0	
4,00	14	40	4,0	
5,00	16	50	5,0	
6,00	18	50	6,0	
8,00	20	63	8,0	
10,00	25	72	10,0	
12,00	30	83	12,0	
16,00	35	92	16,0	
20,00	45	104	20,0	

- 1 Gewindebohrer
- 2 Bohren HSSE
- 3 Bohren VHM
- 4 Reiben HSSE
- 5 Reiben VHM
- 6 Frässtifte VHM
- 7 Alu
- 8 WP-Werkzeuge
- 9 Fräsen HSSE
- 10 Sägen
- 11 Lehren
- 12 Nachschleifen
- 13 Sonstiges

VHM-Formenbau-Mikroschaftfräser 30° kurz

E.7689.1

1.3 6.1 6.2 6.3

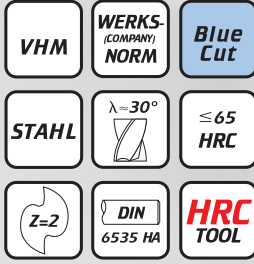

 Solid carbide micro end mills 30° with corner radius for moulds

 Frezy miniaturowe z węgla spiekane go dwuostrzowe krótkie 30° do form

 Microfresce MD con raggio d'angolo per stampi, 30°, serie corta

 Microfresas de metal duro de 30° para moldes, serie corta

Artikel-Nr. Article-No.				E.7689.1 € Stück piece
d1	l2	l1	d2	
0,10	0,3	50	4,0	
0,20	0,5	50	4,0	
0,30	1,0	50	4,0	
0,40	1,0	50	4,0	
0,50	1,5	50	4,0	
0,60	1,5	50	4,0	
0,70	2,0	50	4,0	
0,80	2,0	50	4,0	
0,90	2,5	50	4,0	
1,00	3,0	50	4,0	
1,10	3,0	50	4,0	
1,20	4,0	50	4,0	
1,40	4,0	50	4,0	
1,50	4,0	50	4,0	
1,60	4,0	50	4,0	
1,70	4,0	50	4,0	
1,80	5,0	50	4,0	
1,90	5,0	50	4,0	
2,00	5,0	50	4,0	
2,50	5,0	50	4,0	
3,00	5,0	50	6,0	
4,00	8,0	54	6,0	
5,00	9,0	54	6,0	
6,00	10,0	54	6,0	
8,00	12,0	58	8,0	
10,00	14,0	66	10,0	
12,00	16,0	73	12,0	
14,00	18,0	75	14,0	
16,00	22,0	82	16,0	
20,00	26,0	92	20,0	

VHM-Formenbau-Mikrofräser 30° lang



- Solid carbide micro end mills 30° for moulds long
- Frezy miniaturowe z węgla spiekane-go dwuostrzowe długie 30° do form
- Microfresa MD 30° per stampi, serie lunga
- Microfresas de metal duro de 30° para moldes, serie larga

Artikel-Nr. Article-No.					E.7642.1
d1	l2	l3	l1	d2 h6	€ Stück piece
0,80	1,2	6	45	4,0	
0,90	1,4	6	45	4,0	
1,00	1,5	6	45	4,0	
1,00	1,5	12	45	4,0	
1,20	1,8	8	45	4,0	
1,20	1,8	12	45	4,0	
1,40	2,1	12	45	4,0	
1,50	2,3	14	50	4,0	
1,60	2,4	16	50	4,0	
1,80	2,7	16	50	4,0	
2,00	3,0	8	45	4,0	
2,00	3,0	12	45	4,0	
2,00	3,0	16	50	4,0	
2,00	3,0	20	55	4,0	
2,50	3,7	14	50	4,0	
3,00	4,5	12	45	6,0	
3,00	4,5	20	60	6,0	

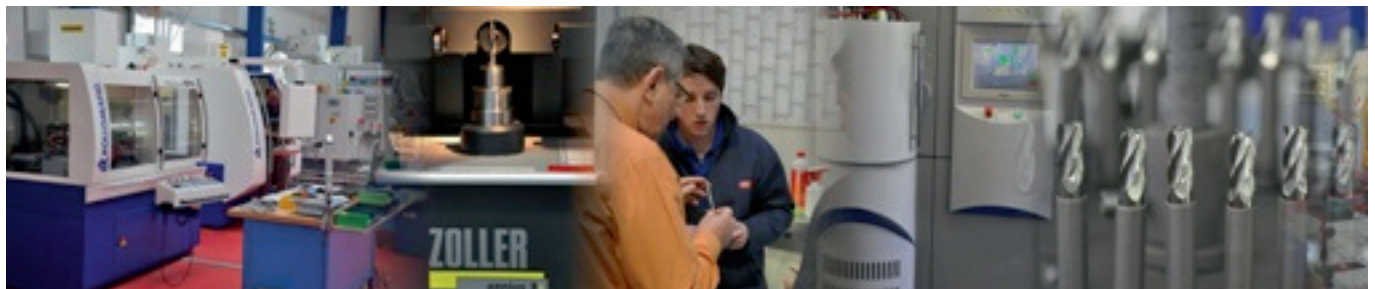

- 1 Gewindebohrer
- 2 Bohren HSSE
- 3 Bohren VHM
- 4 Reiben HSSE
- 5 Reiben VHM
- 6 Frässtifte VHM
- 7 Formenbau
- 8 WP-Werkzeuge
- 9 Fräsen HSSE
- 10 Sägen
- 11 Lehren
- 12 Nachschleifen
- 13 Sonstiges

VHM-Formenbau-Mikroschaftfräser 30° mit Eckenradius kurz



Solid carbide micro end mills 30° with corner radius for moulds short

Frezy miniaturowe z węgla spiekane go dwuostrzowe krótkie 30° z promieniem na czole do form

Microfresce MD 30° per stampi, con raggio d'angolo, serie corta

Microfresas de metal duro de 30° para moldes, serie corta con radio lateral

Artikel-Nr. Article-No.						E.7719.1 € Stück piece
d1	ER	l2	l1	d2		
0,30		0,45	50	6,0		
0,40		0,60	50	6,0		
0,50	0,05	0,70	50	6,0		
0,60	0,05	0,90	50	6,0		
0,80	0,05	1,20	50	6,0		
1,00	0,10	1,50	50	6,0		
1,20	0,10	1,80	50	6,0		
1,50	0,15	2,20	50	6,0		
2,00	0,15	2,20	50	6,0		

VHM-Formenbau-Mikroschaftfräser 30° mit Eckenradius extra kurz

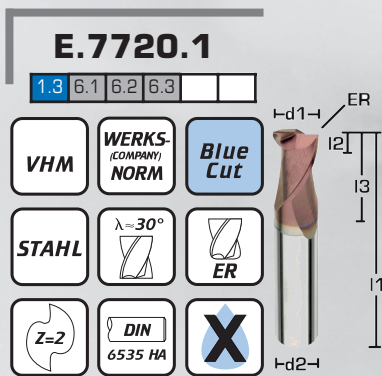

Solid carbide micro end mills 30° with corner radius for moulds extra short

Frezy miniaturowe z węgla spiekane go dwuostrzowe bardzo krótkie 30° z promieniem na czole do form

Microfresce MD 30° per stampi, con raggio d'angolo, serie extra corta

Microfresas de metal duro de 30° para moldes, serie extra corta con radio lateral

Artikel-Nr. Article-No.							E.7720.1 € Stück piece
d1	ER	l2	l3	l1	d2		
0,30		0,45		40	3,0		
0,40		0,60		40	3,0		
0,50	0,05	0,70		40	3,0		
0,60	0,05	0,90		40	3,0		
0,80	0,05	1,20		40	3,0		
1,00	0,10	1,50		40	3,0		
1,50	0,10	2,20		40	3,0		
2,00	0,10	3,00	1,9	40	3,0		
2,50	0,10	4,00	2,4	40	3,0		
3,00	0,10	4,00	2,9	45	6,0		
3,50	0,10	5,00	3,3	45	6,0		
4,00	0,10	5,00	3,8	45	6,0		
4,50	0,10	6,00	4,3	45	6,0		
5,00	0,20	6,00	4,8	50	6,0		
6,00	0,20	7,00	5,8	50	6,0		
8,00	0,20	9,00	7,8	60	8,0		
10,00	0,20	12,00	9,7	75	10,0		
12,00	0,30	15,00	11,7	75	12,0		
16,00	0,30	18,00	15,7	90	16,0		
20,00	0,30	24,00	19,7	100	20,0		

VHM-Formenbau-Mikroschaftfräser 30° mit Eckenradius

E.7640.1

1.3 6.1 6.2 6.3

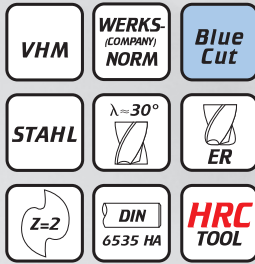

Solid carbide micro end mills 30° with corner radius for moulds

Frezy miniaturowe z węgla spoiekowego dwustrzowe 30° z promieniem na czole do form

Microfresa MD 30° per stampi, con raggio d'angolo

Microfresas de metal duro de 30° para moldes con radio lateral

Frästiefe bis 30xd
Milling depth up to 30xd

Artikel-Nr. Article-No.						E.7640.1
d1	ER	l2	l3	l1	d2	€ Stück piece
0,30	0,05	0,45	1	55	6,0	
0,30	0,05	0,45	2	55	6,0	
0,30	0,05	0,45	3	55	6,0	
0,30	0,05	0,45	5	55	6,0	
0,40	0,05	0,60	2	55	6,0	
0,40	0,05	0,60	4	55	6,0	
0,40	0,05	0,60	6	55	6,0	
0,50	0,05	0,70	2	55	6,0	
0,50	0,05	0,70	4	55	6,0	
0,50	0,05	0,70	6	55	6,0	
0,60	0,06	0,90	2	55	6,0	
0,60	0,06	0,90	4	55	6,0	
0,60	0,06	0,90	6	55	6,0	
0,60	0,06	0,90	8	55	6,0	
0,80	0,08	1,20	2	55	6,0	
0,80	0,08	1,20	4	55	6,0	
0,80	0,08	1,20	6	55	6,0	
0,80	0,08	1,20	8	55	6,0	
0,80	0,08	1,20	10	55	6,0	
1,00	0,10	1,60	3	55	6,0	
1,00	0,10	1,60	4	55	6,0	
1,00	0,10	1,60	5	55	6,0	
1,00	0,10	1,60	6	55	6,0	
1,00	0,10	1,60	8	55	6,0	
1,00	0,10	1,60	10	65	6,0	
1,00	0,10	1,60	12	65	6,0	
1,00	0,10	1,60	15	65	6,0	
1,00	0,10	1,60	20	65	6,0	
1,00	0,10	1,60	25	70	6,0	
1,00	0,10	1,60	30	75	6,0	
1,20	0,12	1,90	4	55	6,0	
1,20	0,12	1,90	6	55	6,0	
1,20	0,12	1,90	8	55	6,0	
1,20	0,12	1,90	10	65	6,0	
1,20	0,12	1,90	12	65	6,0	
1,20	0,12	1,90	15	65	6,0	
1,20	0,12	1,90	20	65	6,0	
1,20	0,12	1,90	25	70	6,0	
1,50	0,15	2,40	5	55	6,0	
1,50	0,15	2,40	6	55	6,0	
1,50	0,15	2,40	8	55	6,0	
1,50	0,15	2,40	10	65	6,0	
1,50	0,15	2,40	12	65	6,0	
1,50	0,15	2,40	15	65	6,0	
1,50	0,15	2,40	20	65	6,0	
1,50	0,15	2,40	25	70	6,0	
1,50	0,15	2,40	30	75	6,0	
2,00	0,20	2,80	6	55	6,0	
2,00	0,20	2,80	8	55	6,0	
2,00	0,20	2,80	10	65	6,0	
2,00	0,20	2,80	12	65	6,0	
2,00	0,20	2,80	15	65	6,0	

- Gewindebohrer 1
- Bohren HSSE 2
- Bohren VHM 3
- Reiben HSSE 4
- Reiben VHM 5
- Frässtifte VHM 6
- Formenbau 7
- WP-Werkzeuge 8
- Fräsen HSSE 9
- Sägen 10
- Lehren 11
- Nachschleifen 12
- Sonstiges 13

VHM-Formenbau-Mikroschaftfräser 30° mit Eckenradius

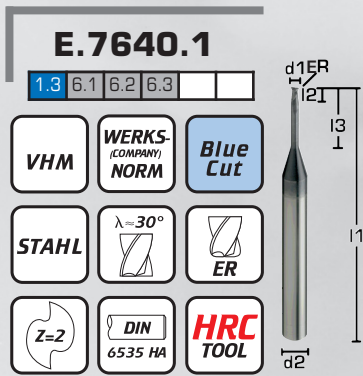

 Solid carbide micro end mills 30° with corner radius for moulds

 Frezy miniaturowe z węglka spiekanego dwuostrzowe 30° z promieniem na czole do form

 Microfresse MD 30° per stampi, con raggio d'angolo

 Microfresas de metal duro de 30° para moldes con radio lateral

Frästiefe bis 30xd
Milling depth up to 30xd

Artikel-Nr. Article-No.						E.7640.1
d1	ER	l2	l3	l1	d2	€ Stück piece
2,00	0,20	2,8	20	65	6,0	
2,00	0,20	2,8	25	70	6,0	
2,00	0,20	2,8	30	75	6,0	
3,00	0,50	3,0	5	55	6,0	
3,00	0,50	3,0	8	55	6,0	
3,00	0,50	3,0	10	65	6,0	
3,00	0,50	3,0	15	65	6,0	
3,00	0,50	3,0	20	65	6,0	
3,00	0,50	3,0	25	70	6,0	
3,00	0,50	3,0	30	75	6,0	
4,00	0,50	4,0	10	65	6,0	
4,00	0,50	4,0	15	65	6,0	
4,00	0,50	4,0	20	65	6,0	
4,00	0,50	4,0	25	70	6,0	
4,00	0,50	4,0	30	75	6,0	
5,00	0,50	5,0	10	65	6,0	
5,00	0,50	5,0	15	65	6,0	
5,00	0,50	5,0	20	65	6,0	
5,00	0,50	5,0	30	75	6,0	
5,00	0,50	5,0	40	90	6,0	
6,00	0,50	6,0	10	65	6,0	
6,00	0,50	6,0	15	65	6,0	
6,00	0,50	6,0	20	65	6,0	
6,00	0,50	6,0	30	75	6,0	
6,00	0,50	6,0	40	90	6,0	
6,00	0,50	6,0	50	90	6,0	

VHM-Formenbau-Schaftfräser 30° kurz

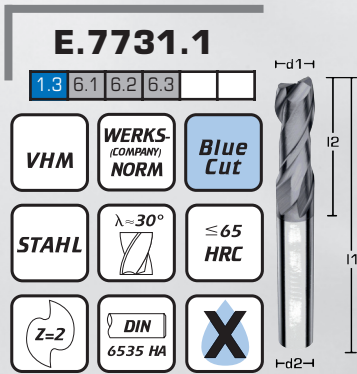

- Solid carbide end mills 30° for moulds short
- Frezy z węgla spiekanego dwuostrzowe krótkie 30° do form
- Frese MD 30° per stampi, serie corta
- Fresas de metal duro de 30° para moldes, serie corta

Artikel-Nr. Article-No.				E.7731.1 € Stück piece
d1	l2	l1	d2	
1,00	2,5	40	6,0	
1,50	4,0	40	6,0	
2,00	6,0	40	6,0	
2,50	8,0	40	6,0	
3,00	8,0	40	6,0	
4,00	11,0	45	6,0	
6,00	13,0	50	6,0	
7,00	16,0	60	8,0	
8,00	19,0	60	8,0	
10,00	19,0	70	10,0	
12,00	22,0	75	12,0	
14,00	26,0	85	14,0	
16,00	32,0	100	16,0	
20,00	38,0	105	20,0	

VHM-Formenbau-Schaftfräser 30° lang

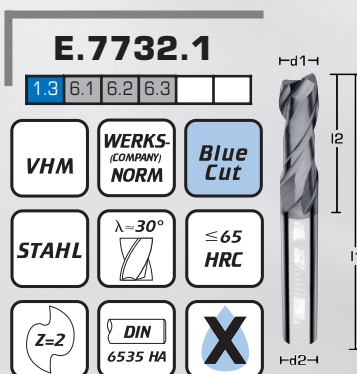

- Solid carbide end mills 30° for moulds long
- Frezy z węgla spiekanego dwuostrzowe długie 30° do form
- Frese MD 30° per stampi, serie lunga
- Fresas de metal duro de 30° para moldes, serie larga

Artikel-Nr. Article-No.				E.7732.1 € Stück piece
d1	l2	l1	d2	
2,00	8	40	4,0	
3,00	12	50	6,0	
4,00	15	50	6,0	
5,00	20	60	6,0	
6,00	20	60	6,0	
8,00	25	70	8,0	
10,00	30	90	10,0	
12,00	30	90	12,0	
14,00	40	110	16,0	
16,00	50	110	16,0	
18,00	50	110	20,0	
20,00	55	110	20,0	
25,00	75	140	25,0	

- Gewindebohrer 1
- Bohren HSSE 2
- Bohren VHM 3
- Reiben HSSE 4
- Reiben VHM 5
- Frässtifte VHM 6
- Formenbau 7
- WP-Werkzeuge 8
- Fräsen HSSE 9
- Sägen 10
- Lehren 11
- Nachschleifen 12
- Sonstiges 13

VHM-Formenbau-Kopierfräser 30° extra lang

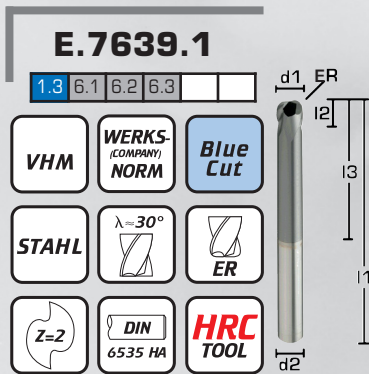

Solid carbide copying end mills 30° for moulds extra long

Frezy z węgla spiekanego dwuostrzowe bardzo długie 30° z promieniem na czole do kopiowania

Frese a copiare MD 30° per stampi, serie extra lunga

Fresas de metal duro de copiado de 30° para moldes, serie extra larga

Artikel-Nr. Article-No.						E.7639.1 € Stück piece
d1	ER	l2	l3	l1	d2 h6	
2,00	0,5	3,0	40	80	6,0	
3,00	0,5	3,5	40	80	6,0	
4,00	1,0	4,0	40	80	6,0	
6,00	2,0	6,0	60	100	8,0	
8,00	2,0	7,0	60	100	8,0	
10,00	3,0	8,0	75	120	10,0	
12,00	4,0	10,0	100	150	16,0	

VHM-Formenbau-Torusfräser 30° mit Eckenradius



Solid carbide torus end mills 30° with corner radius for moulds

Frezy z węgla spiekanego dwuostrzowe torusowe 30° z czolem kulistym do form

Frese toriche Md 30° per stampi, con raggio d'angolo

Fresas tóricas de metal duro de 30° para moldes, con radio lateral





Artikel-Nr. Article-No.					E.7610.1 € Stück piece
d1 h10	ER	l2	l1	d2 h6	
2,00	0,5	4	38	6,0	
3,00	0,5	5	38	6,0	
4,00	0,5	7	38	6,0	
5,00	0,5	8	38	6,0	
6,00	1,0	8	38	6,0	
8,00	2,0	11	43	8,0	
10,00	3,0	13	50	10,0	
12,00	3,0	15	55	12,0	

VHM-Formenbau-Mikroradiusfräser 30° kurz

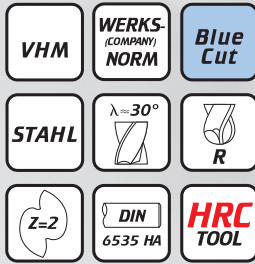
E.7730.1

1.3 6.1 6.2 6.3











-  Solid carbide micro ball nose end mills 30° for moulds short
-  Frezy miniaturowe z węgla spiekanego dwuostrzowe krótkie 30° z czolem kulistym do form
-  Microfresse raggriate MD 30° per stampi, serie corta
-  Microfresas de metal duro de 30° para moldes, con radio, serie corta

Artikel-Nr. Article-No.					E.7730.1 € Stück piece
d1	R	l2	l1	d2 h5	
0,25	0,125	0,5	50	4,0	
0,30	0,150	1,0	50	4,0	
0,40	0,200	1,0	50	4,0	
0,50	0,250	1,5	50	4,0	
0,60	0,300	1,5	50	4,0	
0,70	0,350	2,0	50	4,0	
0,80	0,400	2,0	50	4,0	
0,90	0,450	2,5	50	4,0	
1,00	0,500	3,0	50	4,0	
1,10	0,550	3,0	50	4,0	
1,20	0,600	3,0	50	4,0	
1,40	0,700	4,0	50	4,0	
1,50	0,750	4,0	50	4,0	
1,60	0,800	5,0	50	4,0	
1,80	0,900	5,0	50	4,0	
2,00	1,000	5,0	50	4,0	
2,50	1,250	5,0	50	4,0	
3,00	1,500	6,0	50	6,0	
4,00	2,000	8,0	54	6,0	
5,00	2,500	9,0	54	6,0	
6,00	3,000	10,0	54	6,0	
8,00	4,000	12,0	58	8,0	
10,00	5,000	14,0	66	10,0	
12,00	6,000	16,0	73	12,0	
14,00	7,000	18,0	75	14,0	
16,00	8,000	20,0	82	16,0	
20,00	10,000	24,0	92	20,0	





- Gewindebohrer **1**
- Bohren HSSE **2**
- Bohren VHM **3**
- Reiben HSSE **4**
- Reiben VHM **5**
- Frässtifte VHM **6**
- Formenbau **7**
- WP-Werkzeuge **8**
- Fräsen HSSE **9**
- Sägen **10**
- Lehren **11**
- Nachschleifen **12**
- Sonstiges **13**

E.7605.1

1.3 6.1 6.2 6.3



-  Solid carbide micro ball nose end mills 30° for moulds
-  Frezy miniaturowe z węgla spiekanego dwuostrzowe 30° z czolem kulistym do form
-  Microfrese raggriate MD 30° per stampi
-  Microfresas de metal duro de 30° para moldes, con radio

Artikel-Nr. Article-No.						E.7605.1 € Stück piece
d1	R	l2	l3	l1	d2	
0,30	0,15	0,25	1	55	6,0	
0,30	0,15	0,25	2	55	6,0	
0,30	0,15	0,25	3	55	6,0	
0,30	0,15	0,25	5	55	6,0	
0,40	0,20	0,30	2	55	6,0	
0,40	0,20	0,30	4	55	6,0	
0,40	0,20	0,30	6	55	6,0	
0,50	0,25	0,40	2	55	6,0	
0,50	0,25	0,40	4	55	6,0	
0,50	0,25	0,40	6	55	6,0	
0,60	0,30	0,50	2	55	6,0	
0,60	0,30	0,50	4	55	6,0	
0,60	0,30	0,50	6	55	6,0	
0,60	0,30	0,50	8	55	6,0	
0,80	0,40	0,60	4	55	6,0	
0,80	0,40	0,60	6	55	6,0	
0,80	0,40	0,60	8	55	6,0	
0,80	0,40	0,60	10	55	6,0	
1,00	0,50	0,80	4	55	6,0	
1,00	0,50	0,80	6	55	6,0	
1,00	0,50	0,80	8	55	6,0	
1,00	0,50	0,80	10	65	6,0	
1,00	0,50	0,80	12	65	6,0	
1,00	0,50	0,80	15	65	6,0	
1,00	0,50	0,80	20	65	6,0	
1,00	0,50	0,80	25	70	6,0	
1,00	0,50	0,80	30	75	6,0	
1,20	0,60	1,00	5	55	6,0	
1,20	0,60	1,00	6	55	6,0	
1,20	0,60	1,00	8	55	6,0	
1,20	0,60	1,00	10	65	6,0	
1,20	0,60	1,00	12	65	6,0	
1,20	0,60	1,00	15	65	6,0	
1,20	0,60	1,00	20	65	6,0	
1,20	0,60	1,00	25	70	6,0	
1,50	0,75	1,20	6	55	6,0	
1,50	0,75	1,20	8	55	6,0	
1,50	0,75	1,20	10	65	6,0	
1,50	0,75	1,20	12	65	6,0	
1,50	0,75	1,20	15	65	6,0	
1,50	0,75	1,20	20	65	6,0	
1,50	0,75	1,20	25	65	6,0	
1,50	0,75	1,20	30	70	6,0	
2,00	1,00	1,50	6	55	6,0	
2,00	1,00	1,50	8	55	6,0	
2,00	1,00	1,50	10	65	6,0	
2,00	1,00	1,50	12	65	6,0	
2,00	1,00	1,50	15	65	6,0	
2,00	1,00	1,50	20	65	6,0	
2,00	1,00	1,50	25	70	6,0	
2,00	1,00	1,50	30	75	6,0	

Fortsetzung nächste Seite to be continued

VHM-Formenbau-Mikroradiusfräser 30°

E.7605.1

1.3 6.1 6.2 6.3

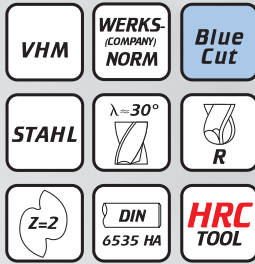

Artikel-Nr. Article-No.						E.7605.1 € Stück piece
d1	R	l2	l3	l1	d2	
3,00	1,50	2,50	5	55	6,0	
3,00	1,50	2,50	10	65	6,0	
3,00	1,50	2,50	15	65	6,0	
3,00	1,50	2,50	20	65	6,0	
3,00	1,50	2,50	25	70	6,0	
3,00	1,50	2,50	30	75	6,0	
4,00	2,00	3,20	10	65	6,0	
4,00	2,00	3,20	15	65	6,0	
4,00	2,00	3,20	20	65	6,0	
4,00	2,00	3,20	25	70	6,0	
4,00	2,00	3,20	30	75	6,0	
5,00	2,50	4,00	10	65	6,0	
5,00	2,50	4,00	15	65	6,0	
5,00	2,50	4,00	20	65	6,0	
5,00	2,50	4,00	25	70	6,0	
5,00	2,50	4,00	30	75	6,0	
5,00	2,50	4,00	40	90	6,0	
6,00	3,00	5,00	10	65	6,0	
6,00	3,00	5,00	15	65	6,0	
6,00	3,00	5,00	20	65	6,0	
6,00	3,00	5,00	25	70	6,0	
6,00	3,00	5,00	30	75	6,0	
6,00	3,00	5,00	40	90	6,0	
6,00	3,00	5,00	50	90	6,0	

- Solid carbide micro ball nose end mills 30° for moulds
- Frezy miniaturowe z węgla spiekanego dwustrzowe 30° z czolem kulistym do form
- Microfresse raggiate MD 30° per stampi
- Microfresas de metal duro de 30° para moldes, con radio

- Gewindebohrer 1
- Bohren HSSE 2
- Bohren VHM 3
- Reiben HSSE 4
- Reiben VHM 5
- Frässtifte VHM 6
- Formenbau 7
- WP-Werkzeuge 8
- Fräsen HSSE 9
- Sägen 10
- Lehren 11
- Nachschleifen 12
- Sonstiges 13

VHM-Formenbau-Mikroradiusfräser 30° kurz

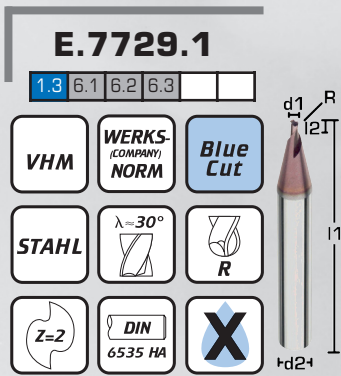

Solid carbide micro ball nose end mills 30° with corner radius for moulds

Frezy miniaturowe z węgla spiekanego dwuostrzowe 30° z czolem kulistym do form

Microfresse raggate MD 30° per stampi, serie corta

Microfresas de metal duro de 30° para moldes, con radio, serie corta

Artikel-Nr. Article-No.					E.7729.1 € Stück piece
d1	R	l2	l1	d2	
0,40	0,20	0,4	50	6,0	
0,50	0,25	0,5	50	6,0	
0,60	0,30	0,6	50	6,0	
0,80	0,40	0,8	50	6,0	
1,00	0,50	1,0	50	6,0	
1,20	0,60	1,2	50	6,0	
1,50	0,75	1,5	50	6,0	
2,00	1,00	2,0	50	6,0	

VHM-Formenbau-Radiusfräser 30° kurz

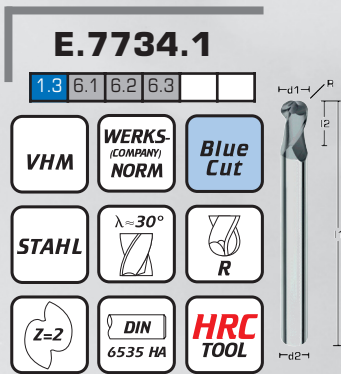

Solid carbide ball nose end mills 30° for moulds short

Frezy z węgla spiekanego dwuostrzowe krótkie 30° z czolem kulistym do form

Frese raggate MD 30° per stampi, serie corta

Fresas de metal duro de 30° para moldes, con radio, serie corta

Artikel-Nr. Article-No.					E.7734.1 € Stück piece
d1	R	l2	l1	d2 h6	
1,00	0,50	1,5	50	6,0	
1,50	0,75	2,5	50	6,0	
2,00	1,00	3,0	50	6,0	
2,50	1,25	4,0	50	6,0	
3,00	1,50	6,0	75	6,0	
4,00	2,00	8,0	75	6,0	
5,00	2,50	10,0	75	6,0	
6,00	3,00	12,0	100	6,0	
8,00	4,00	14,0	100	8,0	
10,00	5,00	18,0	100	10,0	
12,00	6,00	22,0	150	12,0	
14,00	7,00	26,0	150	14,0	
16,00	8,00	30,0	150	16,0	
18,00	9,00	34,0	150	18,0	
20,00	10,00	38,0	150	20,0	

VHM-Formenbau-Radiusfräser 30° lang

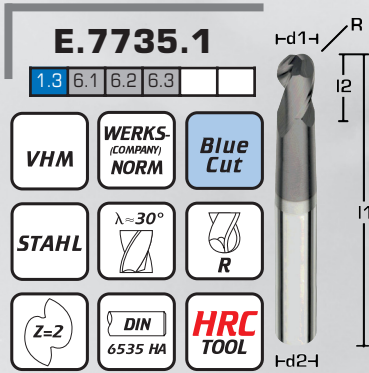

Solid carbide ball nose end mills 30° for moulds long

Frezy z węgla spiekanego dwuostrzowe długie 30° z czolem kulistym do form

Frese raggriate MD 30° per stampi, serie lunga

Fresas de metal duro de 30° para moldes, con radio, serie larga

Artikel-Nr. Article-No.					E.7735.1 € Stück piece
d1	R	l2	l1	d2	
2,00	1,0	5	63	4,0	
3,00	1,5	6	63	4,0	
4,00	2,0	8	76	6,0	
6,00	3,0	9	101	10,0	
8,00	4,0	12	101	10,0	
10,00	5,0	16	101	12,0	
12,00	6,0	20	101	14,0	

VHM-Formenbau-Radiusfräser 30° XL

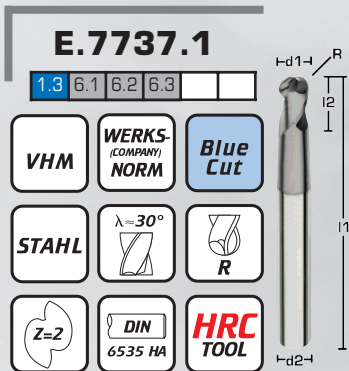

Solid carbide ball nose end milld 30° for moulds XL

Frezy z węgla spiekanego dwuostrzowe bardzo długie 30° z czolem kulistym do form

Frese raggriate MD 30° per stampi, serie extra lunga

Fresas de metal duro de 30° para moldes, con radio, serie extra larga

Artikel-Nr. Article-No.					E.7737.1 € Stück piece
d1	R	l2	l1	d2	
6,00	3,0	9	152	10,0	
8,00	4,0	12	152	10,0	
10,00	5,0	16	152	12,0	
12,00	6,0	20	152	14,0	

- Gewindebohrer 1
- Bohren HSSE 2
- Bohren VHM 3
- Reiben HSSE 4
- Reiben VHM 5
- Frässtifte VHM 6
- Formenbau 7
- WP-Werkzeuge 8
- Fräsen HSSE 9
- Sägen 10
- Lehren 11
- Nachschleifen 12
- Sonstiges 13

VHM-Formenbau X-Tra Radiusfräser 30° kurz

E.7643.1

1.3 6.1 6.2 6.3

VHM WERKS (COMPANY) NORM SPEZIAL BESCHÜTTUNG COATING

STAHL $\lambda = 30^\circ$ R

Z=2 DIN 6535 HA HRC TOOL

- Solid carbide X-Tra ball nose end mills 30° for moulds short
- Frezy z węgla spiekanego dwuostrzowe krótkie 30° z czolem kulistym do form
- Frese raggiate MD "X-Tra" 30° per stampi, serie corta
- Fresas de metal duro "X-Tra" de 30° para moldes, con radio, serie corta

Zum Bohren geeignet
Suitable for drilling

Artikel-Nr. Article-No.					E.7643.1
d1	R	l2	l1	d2 h6	€ Stück piece
0,50	0,25	1,5	38	3,0	
0,60	0,30	1,5	38	3,0	
0,70	0,35	2,0	38	3,0	
0,80	0,40	2,0	38	3,0	
0,90	0,45	2,5	38	3,0	
1,00	0,50	2,0	50	3,0	
1,10	0,55	3,0	50	3,0	
1,20	0,60	3,0	50	3,0	
1,40	0,70	3,0	50	3,0	
1,50	0,75	3,0	50	3,0	
1,60	0,80	4,0	50	3,0	
1,80	0,90	4,0	50	3,0	
2,00	1,00	4,0	50	3,0	
2,50	1,25	5,0	50	3,0	
3,00	1,50	5,0	50	3,0	
4,00	2,00	8,0	54	6,0	
5,00	2,50	9,0	54	6,0	
6,00	3,00	10,0	54	6,0	
8,00	4,00	12,0	58	8,0	
10,00	5,00	14,0	66	10,0	
12,00	6,00	16,0	73	12,0	
14,00	7,00	18,0	75	14,0	
16,00	8,00	22,0	82	16,0	
20,00	10,00	26,0	92	20,0	



VHM-Formenbau X-Tra Radiusfräser 30° lang

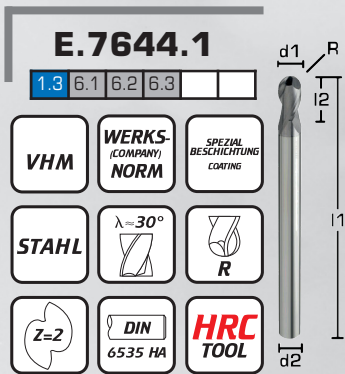

- Solid carbide X-Tra ball nose end mills 30° for moulds long
- Frezy z węgla spiekanego dwuostrzowe długie 30° z czolem kulistym do form
- Frese raggiate MD "X-Tra" 30° per stampi, serie lunga
- Fresas de metal duro "X-Tra" de 30° para moldes, con radio, serie larga

Zum Bohren geeignet
Suitable for drilling

Artikel-Nr. Article-No.					E.7644.1 € Stück piece
d1	R	l2	l1	d2 h6	
1,00	0,50	2	80	6,0	
1,50	0,75	3	80	6,0	
2,00	1,00	4	80	6,0	
2,50	1,25	5	80	6,0	
3,00	1,50	5	80	6,0	
4,00	2,00	8	80	6,0	
5,00	2,50	9	80	6,0	
6,00	3,00	10	100	6,0	
8,00	4,00	12	100	8,0	
10,00	5,00	14	100	10,0	
12,00	6,00	16	100	12,0	
14,00	7,00	18	100	14,0	
16,00	8,00	22	150	16,0	
20,00	10,00	26	150	20,0	

VHM-Formenbau-Kugelfräser 15°

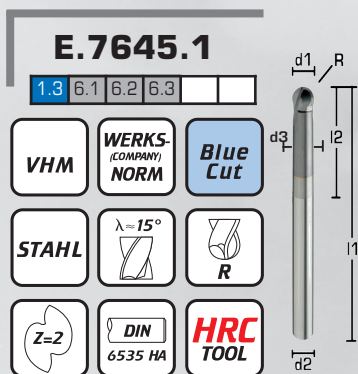

- Solid carbide ball nose end mill 15° for moulds
- Frezy z węgla spiekanego dwuostrzowe 15° z czolem kulistym do form
- Frese raggiate MD 15° per stampi
- Fresas de metal duro de 15° para moldes, con punta bola

Kugel bis 220° einsetzbar
Ball useable up to 220°

Artikel-Nr. Article-No.						E.7645.1 € Stück piece
d1	R	d3	l2	l1	d2 h6	
1,00	0,5	0,9	5	80	6,0	
2,00	1,0	1,8	10	80	6,0	
3,00	1,5	2,8	15	80	6,0	
4,00	2,0	3,8	20	80	6,0	
5,00	2,5	4,7	25	90	6,0	
6,00	3,0	5,7	30	100	6,0	
8,00	4,0	7,5	40	100	8,0	
10,00	5,0	9,4	50	120	10,0	
12,00	6,0	11,2	50	120	12,0	
16,00	8,0	15,0	60	150	16,0	

- Gewindebohrer 1
- Bohren HSSE 2
- Bohren VHM 3
- Reiben HSSE 4
- Reiben VHM 5
- Frässtifte VHM 6
- Formenbau 7
- WP-Werkzeuge 8
- Fräsen HSSE 9
- Sägen 10
- Lehren 11
- Nachschleifen 12
- Sonstiges 13

VHM-Formenbau-Radiuskopierfräser

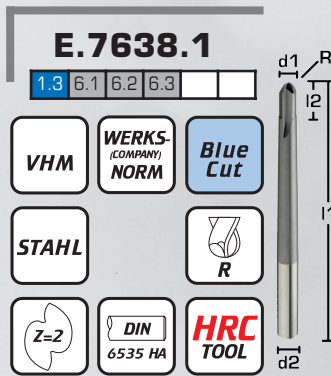

Solid carbide ball nose copying end mills for moulds

Frezy z węgla spiekanego dwuostrzowe z czółem kulistym do form i kopiowania

Frese raggiate a copiare MD per stampi

Fresas de metal duro para moldes con radio para copiado

Artikel-Nr. Article-No.					E.7638.1 € Stück piece
d1	R	l2	l1	d2 h6	
3,00	1,5	5	75	6,0	
4,00	2,0	6	75	6,0	
5,00	2,5	8	75	6,0	
6,00	3,0	10	75	6,0	
8,00	4,0	12	85	10,0	
10,00	5,0	18	100	12,0	
<i>lang long</i>					E.7638.1L
3,00	1,5	5	100	6,0	
4,00	2,0	6	100	6,0	
5,00	2,5	8	100	6,0	
6,00	3,0	10	100	6,0	
8,00	4,0	12	150	10,0	
10,00	5,0	18	150	12,0	

VHM-Formenbau-Kugelfräser 30°

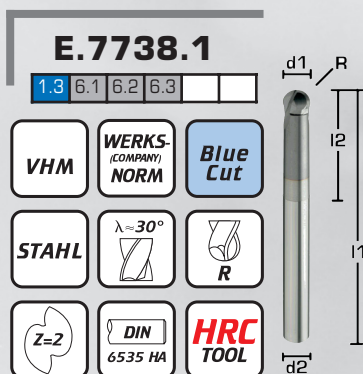

Solid carbide ball nose end mills 30° for moulds

Frezy z węgla spiekanego dwuostrzowe 30° z czółem kulistym do form

Frese raggiate MD 30° per stampi

Fresas de metal duro de 30° para moldes con punta bola

Artikel-Nr. Article-No.					E.7738.1 € Stück piece
d1	R	l2	l1	d2 h6	
3,00	1,50	7	60	6,0	
4,00	2,00	9	60	6,0	
5,00	2,50	12	60	6,0	
6,00	3,00	15	70	8,0	
8,00	4,00	21	70	10,0	
10,00	5,00	25	70	12,0	
12,00	6,00	30	90	12,0	

VHM-Formenbau-Schaftfräser 38°

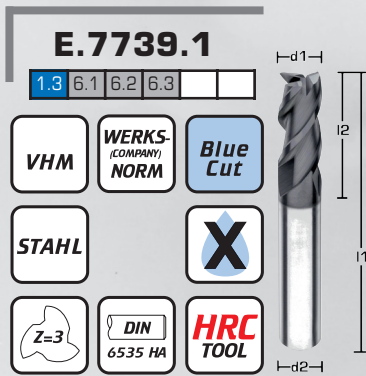

Solid carbide end mills 38° for moulds

Frezy z węglika spiekanego trzyostrzowe 38° do form

Frese in MD 38° per stampi

Fresas de metal duro de 38° para moldes

Artikel-Nr. Article-No.				E.7739.1 € Stück piece
d1	l2	l1	d2	
1,00	2,5	38	3,0	
1,50	5,0	50	4,0	
2,50	7,0	38	3,0	
3,00	10,0	38	3,0	
3,00	10,0	50	6,0	
3,50	12,0	50	6,0	
4,00	12,0	50	4,0	
5,00	14,0	50	5,0	
6,00	16,0	57	6,0	
8,00	20,0	63	8,0	
10,00	22,0	72	10,0	
12,00	25,0	73	12,0	
14,00	25,0	75	14,0	
16,00	32,0	82	16,0	
18,00	32,0	92	18,0	
20,00	38,0	92	20,0	

VHM-Formenbau-Radiusfräser 30°

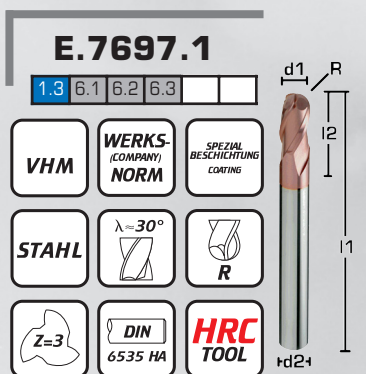

Solid carbide ball nose end mills 30° for moulds

Frezy z węglika spiekanego trzyostrzowe 30° z czółem kulistym do form

Frese in MD raggiate 30° per stampi

Fresas de metal duro de 30° para moldes con radio

Artikel-Nr. Article-No.					E.7697.1 € Stück piece
d1	R + - 0,015	l2	l1	d2 h6	
3,00	1,5	8	60	6,0	
4,00	2,0	8	70	6,0	
5,00	2,5	10	80	6,0	
6,00	3,0	12	90	6,0	
8,00	4,0	14	100	8,0	
10,00	5,0	18	100	10,0	
12,00	6,0	22	110	12,0	
16,00	8,0	30	140	16,0	
20,00	10,0	38	160	20,0	

- 1 Gewindebohrer
- 2 Bohren HSSE
- 3 Bohren VHM
- 4 Reiben HSSE
- 5 Reiben VHM
- 6 Frässtifte VHM
- 7 Formenbau
- 8 WP-Werkzeuge
- 9 Fräsen HSSE
- 10 Sägen
- 11 Lehren
- 12 Nachschleifen
- 13 Sonstiges

VHM-Formenbau-Schaftfräser 45° kurz

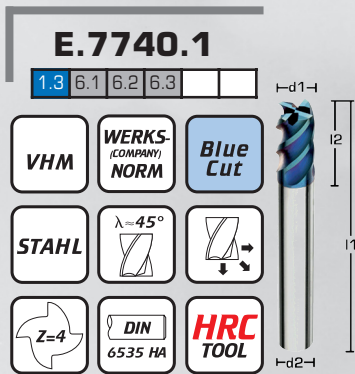

Solid carbide end mills 45° for moulds short

Frezy z węgla spiekane czterostrzowe krótkie 45° do form

Frese in MD 45° per stampi, serie corta

Fresas de metal duro de 45° para moldes, serie corta

Artikel-Nr. Article-No.				E.7740.1 € Stück piece
d1	l2	l1	d2 h5	
1,00	3	54	6,0	
2,00	4	54	6,0	
3,00	5	54	6,0	
4,00	6	54	6,0	
5,00	7	54	6,0	
6,00	10	54	6,0	
8,00	12	58	8,0	
10,00	15	66	10,0	
12,00	18	73	12,0	
16,00	24	82	16,0	
20,00	32	92	20,0	

VHM-Formenbau-Schaftfräser 30° kurz

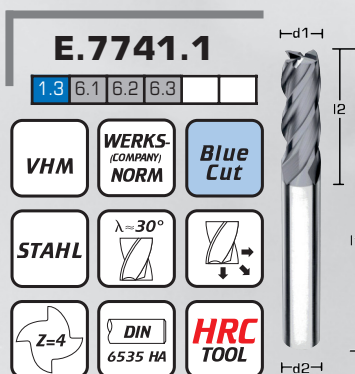

Solid carbide end mills 30° for moulds short

Frezy z węgla spiekane czterostrzowe krótkie 30° do form

Frese in MD 30° per stampi, serie corta

Fresas de metal duro de 30° para moldes, serie corta

Artikel-Nr. Article-No.				E.7741.1 € Stück piece
d1	l2	l1	d2	
2,00	6	40	6,0	
2,50	8	40	6,0	
3,00	8	45	6,0	
3,50	10	45	6,0	
4,00	11	45	6,0	
5,00	13	50	6,0	
6,00	13	50	6,0	
7,00	16	60	8,0	
8,00	19	60	8,0	
9,00	19	70	10,0	
10,00	22	70	10,0	
11,00	22	75	12,0	
12,00	26	75	12,0	
14,00	26	85	14,0	
16,00	32	100	16,0	
18,00	32	100	18,0	
20,00	38	105	20,0	
25,00	45	120	25,0	

VHM-Formenbau-Schaftfräser 30° lang

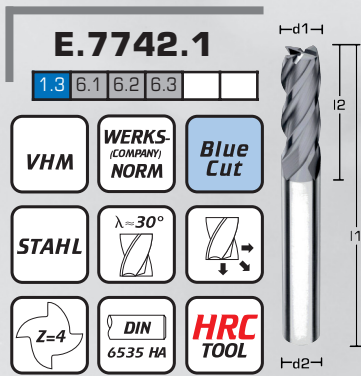

- Solid carbide end mills 30° for moulds long
- Frezy z węgla spiekanego czterostrzowe długie 30° do form
- Frese in MD 30° per stampi, serie lunga
- Fresas de metal duro de 30° para moldes, serie larga

Artikel-Nr. Article-No.				E.7742.1 € Stück piece
d1	l2	l1	d2	
2,00	8	40	4,0	
3,00	12	50	6,0	
4,00	15	50	6,0	
5,00	20	60	6,0	
6,00	20	60	6,0	
8,00	25	70	8,0	
10,00	30	90	10,0	
12,00	30	90	12,0	
14,00	40	110	16,0	
16,00	50	110	16,0	
18,00	50	110	20,0	
20,00	55	110	20,0	
25,00	75	140	25,0	

VHM-Formenbau-Schaftfräser 30° mit Eckenradius

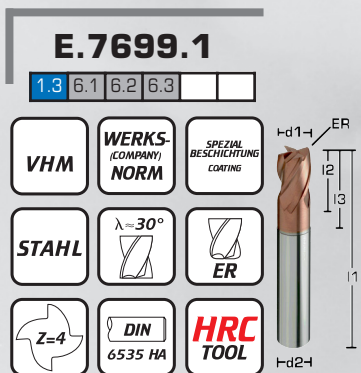





- Solid carbide end mills 30° with corner radius for moulds
- Frezy z węgla spiekanego czterostrzowe 30° z promieniem na czole do form
- Frese MD 30° per stampi con raggio d'angolo
- Fresas de metal duro de 30° para moldes, con radio lateral

Artikel-Nr. Article-No.						E.7699.1 € Stück piece
d1	ER	l2	l3	l1	d2 h6	
1,00	0,1	1,5	1,5	40	3,0	
1,50	0,1	2,2	2,2	40	3,0	
2,00	0,1	3,0	6,0	40	3,0	
2,50	0,1	4,0	6,0	40	3,0	
3,00	0,1	4,0	7,0	45	6,0	
3,50	0,1	5,0	9,0	45	6,0	
4,00	0,1	5,0	9,0	45	6,0	
4,50	0,1	6,0	10,0	45	6,0	
5,00	0,2	6,0	11,0	50	6,0	
6,00	0,2	7,0	14,0	50	6,0	
8,00	0,2	9,0	18,0	60	8,0	
10,00	0,2	12,0	25,0	75	10,0	
12,00	0,3	15,0	30,0	75	12,0	
16,00	0,3	18,0	38,0	90	16,0	
20,00	0,3	24,0	45,0	100	20,0	

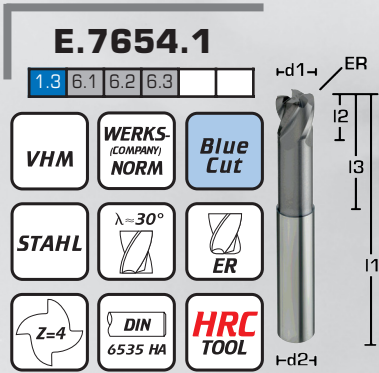
- 1 Gewindebohrer
- 2 Bohren HSSE
- 3 Bohren VHM
- 4 Reiben HSSE
- 5 Reiben VHM
- 6 Frässtifte VHM
- 7 Formenbau
- 8 WP-Werkzeuge
- 9 Fräsen HSSE
- 10 Sägen
- 11 Lehren
- 12 Nachschleifen
- 13 Sonstiges

VHM-Formenbau-Kopierfräser 30° mit Eckenradius



-  Solid carbide end mills 30° with corner radius for moulds
-  Frezy z węgla spiekanego czterostrzowe 30° z promieniem na czole do form i kopiowania
-  Frese a copiare MD 30° con raggio d'angolo per stampi
-  Fresas de metal duro de 30° para moldes, con radio lateral para copiado

Artikel-Nr. Article-No.						E.7654.1 € Stück piece
d1	ER	l2	l3	l1	d2	
2,00	0,1	4	21	57	6,0	
2,00	0,2	4	21	57	6,0	
2,00	0,3	4	21	57	6,0	
2,00	0,4	4	21	57	6,0	
2,00	0,5	4	21	57	6,0	
3,00	0,1	6	21	57	6,0	
3,00	0,2	6	21	57	6,0	
3,00	0,3	6	21	57	6,0	
3,00	0,4	6	21	57	6,0	
3,00	0,5	6	21	57	6,0	
3,00	1,0	6	21	57	6,0	
4,00	0,1	6	21	57	6,0	
4,00	0,2	6	21	57	6,0	
4,00	0,3	6	21	57	6,0	
4,00	0,4	6	21	57	6,0	
4,00	0,5	6	21	57	6,0	
4,00	0,6	6	21	57	6,0	
4,00	0,7	6	21	57	6,0	
4,00	0,8	6	21	57	6,0	
4,00	0,9	6	21	57	6,0	
4,00	1,0	6	21	57	6,0	
4,00	1,1	6	21	57	6,0	
4,00	1,2	6	21	57	6,0	
4,00	1,3	6	21	57	6,0	
4,00	1,4	6	21	57	6,0	
4,00	1,5	6	21	57	6,0	
5,00	0,1	6	21	57	6,0	
5,00	0,2	6	21	57	6,0	
5,00	0,3	6	21	57	6,0	
5,00	0,4	6	21	57	6,0	
5,00	0,5	6	21	57	6,0	
5,00	1,0	6	21	57	6,0	
5,00	1,5	6	21	57	6,0	
5,00	2,0	6	21	57	6,0	
6,00	0,1	7	21	57	6,0	
6,00	0,2	7	21	57	6,0	
6,00	0,3	7	21	57	6,0	
6,00	0,4	7	21	57	6,0	
6,00	0,5	7	21	57	6,0	
6,00	0,6	7	21	57	6,0	
6,00	0,7	7	21	57	6,0	
6,00	0,8	7	21	57	6,0	
6,00	0,9	7	21	57	6,0	
6,00	1,0	7	21	57	6,0	
6,00	1,1	7	21	57	6,0	
6,00	1,2	7	21	57	6,0	
6,00	1,3	7	21	57	6,0	
6,00	1,4	7	21	57	6,0	
6,00	1,5	7	21	57	6,0	
6,00	1,6	7	21	57	6,0	
6,00	1,7	7	21	57	6,0	

Fortsetzung nächste Seite to be continued



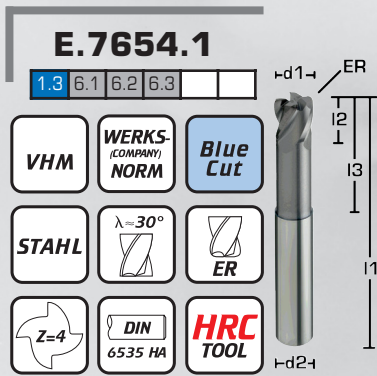

VHM-Formenbau-Kopierfräser 30° mit Eckenradius

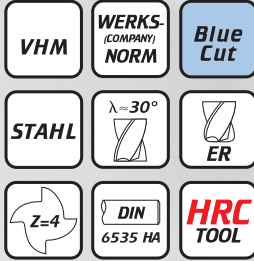

E.7654.1

1.3 6.1 6.2 6.3



-  Solid carbide copying end mills 30° with corner radius for moulds
-  Frezy z węgla spiekane go czterostrzowe 30° z promieniem na czole do form i kopiowania
-  Frese a copiare MD 30° con raggio d'angolo per stampi
-  Fresas de metal duro de 30° para moldes, con radio lateral para copiado

Artikel-Nr. Article-No.						E.7654.1
d1	ER	l2	l3	l1	d2	€ Stück piece
6,00	1,8	7	21	57	6,0	
6,00	1,9	7	21	57	6,0	
6,00	2,0	7	21	57	6,0	
6,00	2,1	7	21	57	6,0	
6,00	2,2	7	21	57	6,0	
6,00	2,3	7	21	57	6,0	
6,00	2,4	7	21	57	6,0	
6,00	2,5	7	21	57	6,0	
8,00	0,3	9	27	63	8,0	
8,00	0,5	9	27	63	8,0	
8,00	1,0	9	27	63	8,0	
8,00	1,5	9	27	63	8,0	
8,00	2,0	9	27	63	8,0	
10,00	0,5	11	32	72	10,0	
10,00	1,0	11	32	72	10,0	
10,00	1,5	11	32	72	10,0	
10,00	2,0	11	32	72	10,0	
12,00	0,5	12	38	83	12,0	
12,00	1,0	12	38	83	12,0	
12,00	1,5	12	38	83	12,0	
12,00	2,0	12	38	83	12,0	
16,00	0,5	16	44	92	16,0	
16,00	1,0	16	44	92	16,0	
16,00	1,5	16	44	92	16,0	
16,00	2,0	16	44	92	16,0	

Gewindebohrer	1
Bohren HSSE	2
Bohren VHM	3
Reiben HSSE	4
Reiben VHM	5
Frässtifte VHM	6
Formenbau	7
WP-Werkzeuge	8
Fräsen HSSE	9
Sägen	10
Lehren	11
Nachschleifen	12
Sonstiges	13

VHM-Formenbau-Kopierfräser 30° mit Eckenradius lang

E.7733.1

1.3 6.1 6.2 6.3

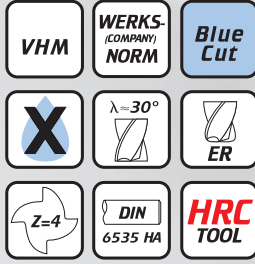

Solid carbide copying end mills 30° with corner radius for moulds long

Frezy z węgla spiekanego czterostrzowe długie 30° z promieniem na czole do form i kopiowania

Frese a copiare MD 30° con raggio d'angolo per stampi, serie lunga

Fresas de metal duro de 30° para moldes, con radio lateral para copiado, serie larga





Artikel-Nr. Article-No.						E.7633.1
d1	ER	l2	l3	l1	d2	€ Stück piece
2,00	0,1	4	11	50	6,0	
2,00	0,2	4	11	50	6,0	
2,00	0,3	4	11	50	6,0	
2,00	0,4	4	11	50	6,0	
3,00	0,2	4	11	50	6,0	
3,00	0,3	4	11	50	6,0	
3,00	0,4	4	11	50	6,0	
3,00	0,5	4	11	50	6,0	
3,00	1,0	4	11	50	6,0	
4,00	0,1	6	11	50	6,0	
4,00	0,2	6	11	50	6,0	
4,00	0,3	6	11	50	6,0	
4,00	0,4	6	11	50	6,0	
4,00	0,5	6	11	50	6,0	
4,00	0,6	6	11	50	6,0	
4,00	0,8	6	11	50	6,0	
4,00	1,0	6	11	50	6,0	
4,00	1,5	6	11	50	6,0	
5,00	0,2	6	11	50	6,0	
5,00	0,3	6	11	50	6,0	
6,00	0,1	7	11	50	6,0	
6,00	0,2	7	11	50	6,0	
6,00	0,3	7	11	50	6,0	
6,00	0,4	7	11	50	6,0	
6,00	0,5	7	11	50	6,0	
6,00	0,6	7	11	50	6,0	
6,00	0,7	7	11	50	6,0	
6,00	0,8	7	11	50	6,0	
6,00	0,9	7	11	50	6,0	
6,00	1,0	7	11	50	6,0	
6,00	1,1	7	11	50	6,0	
6,00	1,2	7	11	50	6,0	
6,00	1,3	7	11	50	6,0	
6,00	1,4	7	11	50	6,0	
6,00	1,5	7	11	50	6,0	
6,00	1,6	7	11	50	6,0	
6,00	1,7	7	11	50	6,0	
6,00	1,8	7	11	50	6,0	
6,00	1,9	7	11	50	6,0	
6,00	2,0	7	11	50	6,0	
6,00	2,1	7	11	50	6,0	
6,00	2,2	7	11	50	6,0	
6,00	2,3	7	11	50	6,0	
6,00	2,4	7	11	50	6,0	
6,00	2,5	7	11	50	6,0	
8,00	0,5	9	13	58	8,0	
8,00	1,0	9	13	58	8,0	
8,00	1,5	9	13	58	8,0	
8,00	2,0	9	13	58	8,0	
10,00	0,5	11	15	66	10,0	
10,00	1,0	11	15	66	10,0	
10,00	1,5	11	15	66	10,0	
10,00	2,0	11	15	66	10,0	

VHM-Formenbau-Schaftfräser 30° mit Eckenradius

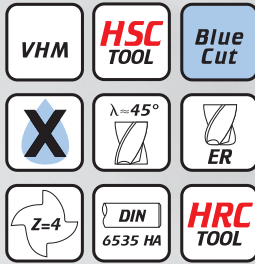
E.7743.1

1.3 6.1 6.2 6.3



-  Solid carbide end mills 30° with corner radius for moulds
-  Frezy z węgla spiekane go czterostrzowe 30° z promieniem na czole do form
-  Frese MD per stampi con raggio d'angolo 30°
-  Fresas de metal duro de 30° para moldes, con radio lateral

Artikel-Nr. Article-No.						E.7743.1
d1	ER	l2	l3	l1	d2 h5	€ Stück piece
2,00	0,2	6	12	57	6,0	
2,00	0,3	6	12	57	6,0	
3,00	0,3	8	15	57	6,0	
3,00	0,5	8	15	57	6,0	
4,00	0,2	11	21	57	6,0	
4,00	0,3	11	21	57	6,0	
4,00	0,5	11	21	57	6,0	
4,00	1,0	11	21	57	6,0	
5,00	0,2	12	21	57	6,0	
5,00	0,5	12	21	57	6,0	
5,00	1,0	12	21	57	6,0	
6,00	0,1	12	21	57	6,0	
6,00	0,2	12	21	57	6,0	
6,00	0,3	12	21	57	6,0	
6,00	0,5	12	21	57	6,0	
6,00	1,0	12	21	57	6,0	
6,00	2,0	12	21	57	6,0	
8,00	0,3	15	15	75	8,0	
8,00	0,5	15	15	75	8,0	
8,00	1,0	15	15	75	8,0	
8,00	1,5	15	15	75	8,0	
8,00	2,0	15	15	75	8,0	
10,00	0,5	17	17	75	10,0	
10,00	1,0	17	17	80	10,0	
10,00	1,5	17	17	80	10,0	
10,00	2,0	17	17	80	10,0	
12,00	0,5	20	20	100	12,0	
12,00	1,0	20	20	100	12,0	
12,00	1,5	20	20	100	12,0	
12,00	2,0	20	20	100	12,0	
16,00	1,0	25	25	110	16,0	
16,00	1,5	25	25	110	16,0	
16,00	2,0	25	25	110	16,0	
16,00	3,0	25	25	110	16,0	
20,00	1,0	32	32	125	20,0	

- Gewindebohrer 1
- Bohren HSSE 2
- Bohren VHM 3
- Reiben HSSE 4
- Reiben VHM 5
- Frässtifte VHM 6
- Formenbau 7
- WP-Werkzeuge 8
- Fräsen HSSE 9
- Sägen 10
- Lehren 11
- Nachschleifen 12
- Sonstiges 13

VHM-Formenbau-Kopierfräser 30° lang

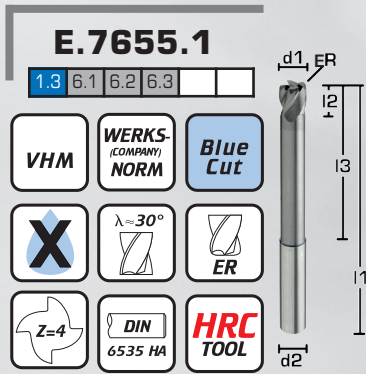

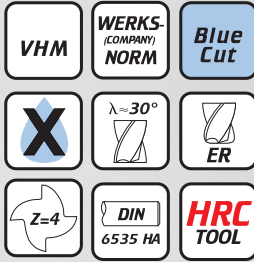

E.7655.1

1.3 6.1 6.2 6.3



 Solid carbide copying end mills 30° for moulds long

 Frezy z węgla spiekanego czterostrzowe długie 30° z promieniem na czole do form i kopiowania

 Frese MD a copiare 30° per stampi, serie lunga

 Fresas de metal duro de 30° para moldes para copiado, serie larga

Artikel-Nr. Article-No.						E.7655.1 € Stück piece
d1	ER	l2	l3	l1	d2 h6	
6,00	0,1	7	44	80	6,0	
6,00	0,2	7	44	80	6,0	
6,00	0,3	7	44	80	6,0	
6,00	0,4	7	44	80	6,0	
6,00	0,5	7	44	80	6,0	
6,00	0,6	7	44	80	6,0	
6,00	0,7	7	44	80	6,0	
6,00	0,8	7	44	80	6,0	
6,00	0,9	7	44	80	6,0	
6,00	1,0	7	44	80	6,0	
6,00	1,1	7	44	80	6,0	
6,00	1,2	7	44	80	6,0	
6,00	1,3	7	44	80	6,0	
6,00	1,4	7	44	80	6,0	
6,00	1,5	7	44	80	6,0	
6,00	1,6	7	44	80	6,0	
6,00	1,7	7	44	80	6,0	
6,00	1,8	7	44	80	6,0	
6,00	1,9	7	44	80	6,0	
6,00	2,0	7	44	80	6,0	
6,00	2,1	7	44	80	6,0	
6,00	2,2	7	44	80	6,0	
6,00	2,3	7	44	80	6,0	
6,00	2,4	7	44	80	6,0	
6,00	2,5	7	44	80	6,0	
8,00	1,0	9	54	100	8,0	
8,00	1,5	9	54	100	8,0	
8,00	2,0	9	54	100	8,0	
10,00	1,0	11	60	100	10,0	
10,00	1,5	11	60	100	10,0	
10,00	2,0	11	60	100	10,0	
12,00	1,0	12	75	120	12,0	
12,00	1,5	12	75	120	12,0	
12,00	2,0	12	75	120	12,0	
16,00	2,0	16	92	120	16,0	

VHM-Formenbau-Stirn-Torusfräser

E.7744.1

1.3 6.1 6.2 6.3



Solid carbide face torus end mills for moulds

Frezy z węgliką spiekanego cztero-rostrzowe torusowe z promieniem na czole do form

Frese toriche frontali MD per stampi

Fresas frontales tóricas de metal duro para moldes

Artikel-Nr. Article-No.						E.7744.1 € Stück piece
d1	ER	l2	l3	l1	d2	
6,00	1,0	9	16	54	6,0	
8,00	1,0	12	20	58	8,0	
10,00	1,5	15	24	66	10,0	
12,00	1,5	18	26	73	12,0	
16,00	2,0	24	32	82	16,0	
20,00	2,0	30	40	92	20,0	

VHM-Formenbau-Radiusfräser

E.7745.1

1.3 6.1 6.2 6.3

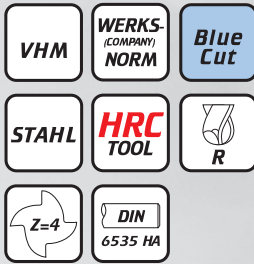

Solid carbide ball nose end mills for moulds

Frezy z węgliką spiekanego cztero-rostrzowe z czołem kulistym do form

Frese raggriate MD per stampi

Fresas de metal duro para moldes, con radio

Artikel-Nr. Article-No.					E.7745.1 € Stück piece
d1	R	l2	l1	d2	
3,00	1,5	6	60	6,0	
4,00	2,0	8	60	6,0	
5,00	2,5	10	70	6,0	
6,00	3,0	12	70	6,0	
8,00	4,0	12	75	8,0	
10,00	5,0	16	80	10,0	
12,00	6,0	16	120	12,0	

- Gewindebohrer 1
- Bohren HSSE 2
- Bohren VHM 3
- Reiben HSSE 4
- Reiben VHM 5
- Frässtifte VHM 6
- Formenbau 7
- WP-Werkzeuge 8
- Fräsen HSSE 9
- Sägen 10
- Lehren 11
- Nachschleifen 12
- Sonstiges 13

VHM-Formenbau-Kugelfräser 15° extra lang

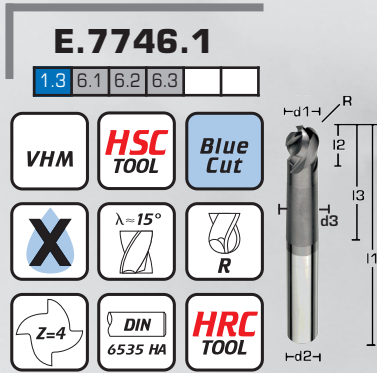

Solid carbide ball nose end mills 15° for moulds extra long

Frezy z węgla spiekanego czterostrzowe bardzo długie 15° z czolem kulistym do form

Frese raggiate MD 15° per stampi, serie extra lunga

Fresas de metal duro de 15° para moldes con punta bola, serie extra larga

Artikel-Nr. Article-No.						E.7746.1
d1	R	d3	l3	l1	d2	€ Stück <i>piece</i>
5,00	2,5	4,7	25	80	6,0	
6,00	3,0	5,7	30	100	6,0	
8,00	4,0	7,5	40	100	8,0	
10,00	5,0	9,4	50	100	10,0	
12,00	6,0	11,2	50	100	12,0	
16,00	8,0	15,0	60	150	16,0	



VHM-Formenbau-Schaftfräser 50°

E.7682.1

1.2 1.3 6.1 6.2 6.3

VHM WERKS (COMPANY) NORM Blue Cut

STAHL $\lambda = 50^\circ$

HEBIR SCHNEIDER DIN 6535 HA HRC TOOL

- Solid carbide end mills 50° for moulds
- Frezy z węglika spiekanego wieloostrowe 50° do form
- Frese MD 50° per stampi
- Fresas de metal duro de 50° para moldes

Artikel-Nr. Article-No.					E.7682.1
d1	l2	l1	d2 h6	Zähne flutes	€ Stück piece
4,00	10	54	6,0	6	
5,00	10	54	6,0	6	
6,00	10	54	6,0	6	
7,00	12	58	8,0	6	
8,00	12	58	8,0	6	
9,00	14	66	10,0	6	
10,00	14	66	10,0	6	
12,00	16	73	12,0	6	
14,00	20	82	16,0	8	
16,00	20	82	16,0	8	
18,00	25	92	20,0	8	
20,00	25	92	20,0	8	
lang long					E.7682.1L
6,00	18	57	6,0	6	
8,00	24	63	8,0	6	
10,00	30	75	10,0	6	
12,00	36	83	12,0	6	
12,00	53	110	12,0	6	
16,00	48	104	16,0	8	
16,00	63	123	16,0	8	
20,00	55	110	20,0	8	
20,00	75	141	20,0	10	
überlang extended long					E.7682.1XL
10,00	45	95	10,0	6	
12,00	36	150	12,0	6	
16,00	65	150	16,0	8	
16,00	80	135	16,0	8	
20,00	100	166	20,0	10	
20,00	125	191	20,0	10	
25,00	175	255	25,0	12	

- Gewindebohrer 1
- Bohren HSSE 2
- Bohren VHM 3
- Reiben HSSE 4
- Reiben VHM 5
- Frässtifte VHM 6
- Formenbau 7
- WP-Werkzeuge 8
- Fräsen HSSE 9
- Sägen 10
- Lehren 11
- Nachschleifen 12
- Sonstiges 13

VHM-Formenbau-Spezial-Schaftfräser 45°

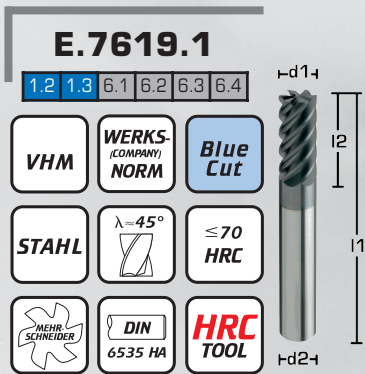

Solid carbide special end mills 45° for moulds

Frezy specjalne z węglika spiekanego wieloostrzowe 45° do form

Frese in MD speciali 45° per stampi

Fresas de metal duro especiales de 45° para moldes

Artikel-Nr. Article-No.					E.7619.1 € Stück piece
d1	l2	l1	d2 h6	Zähne flutes	
2,00	6	57	6,0	4	
3,00	8	57	6,0	4	
4,00	8	57	6,0	6	
5,00	10	57	6,0	6	
6,00	13	57	6,0	6	
8,00	19	63	6,0	6	
10,00	22	72	10,0	6	
12,00	26	83	12,0	6	
16,00	32	92	16,0	8	
20,00	38	104	20,0	8	
25,00	40	110	25,0	8	
32,00	40	110	32,0	8	

VHM-Formenbau-Schaftfräser 45° mit Eckenradius

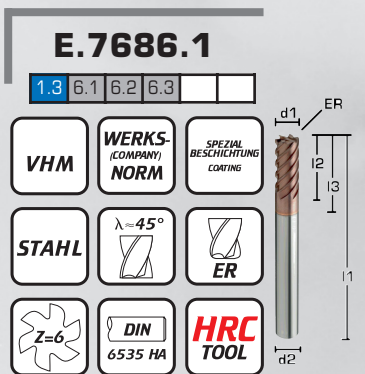

Solid carbide end mills 45° with corner radius for moulds

Frezy z węglika spiekanego sześciostrzowe 45° z promieniem na czole do form

Frese MD 45° per stampi con raggio d'angolo

Fresas de metal duro de 45° para moldes con radio lateral

Artikel-Nr. Article-No.						E.7686.1 € Stück piece
d1	ER	l2	l3	l1	d2 h6	
6,00	0,5	6	14	50	6,0	
6,00	0,5	13	13	70	6,0	
6,00	0,5	26	26	70	6,0	
8,00	0,5	8	24	60	8,0	
8,00	0,5	19	19	90	8,0	
8,00	0,5	36	36	90	8,0	
10,00	0,5	22	22	100	10,0	
10,00	1,0	22	22	100	10,0	
10,00	1,0	46	46	100	10,0	
10,00	1,0	10	30	70	10,0	
12,00	0,5	26	26	110	12,0	
12,00	1,0	26	26	110	12,0	
12,00	1,0	56	56	110	12,0	
12,00	1,0	12	30	75	12,0	
16,00	1,0	32	32	130	16,0	
16,00	1,5	66	66	130	16,0	

VHM-Formenbau-Torusfräser 45° mit Eckenradius

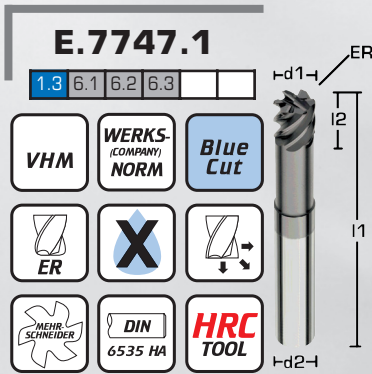

- Solid carbide torus end mills 45° with corner radius for moulds
- Frezy z węglika spiekanego wielostrzowe 45° z promieniem na czole do form
- Frese toriche MD 45° per stampi con raggio d'angolo
- Fresas tóricas de metal duro para moldes de 45° con radio lateral

Artikel-Nr. Article-No.						E.7747.1 € Stück piece
d1	ER	l2	l1	d2	Zähne flutes	
3,00	0,3	4	50	6,0	4	
4,00	0,4	5	54	6,0	4	
5,00	0,5	6	54	6,0	4	
6,00	0,5	7	65	6,0	6	
6,00	1,0	7	65	6,0	6	
8,00	0,5	9	70	8,0	6	
8,00	1,0	9	70	8,0	6	
10,00	0,5	11	80	10,0	6	
10,00	1,0	11	80	10,0	6	
10,00	1,5	11	80	10,0	6	
10,00	2,0	11	80	10,0	6	
12,00	0,5	12	93	12,0	6	
12,00	1,0	12	93	12,0	6	
12,00	1,5	12	93	12,0	6	
12,00	2,0	12	93	12,0	6	



- Gewindebohrer 1
- Bohren HSSE 2
- Bohren VHM 3
- Reiben HSSE 4
- Reiben VHM 5
- Frässtifte VHM 6
- Formenbau 7
- WP-Werkzeuge 8
- Fräsen HSSE 9
- Sägen 10
- Lehren 11
- Nachschleifen 12
- Sonstiges 13

VHM-Formenbau-Schaftfräser 50° mit Eckenradius lang

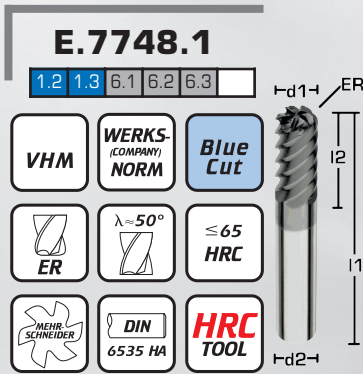

Solid carbide end mills 50° with corner radius for moulds long

Frezy z węgla spiekanego wieloostrzowe długie 45° z promieniem na czole do form

Frese MD per stampi con raggio d'angolo, serie lunga

Fresas de metal duro de 50° para moldes con radio lateral, serie larga

Artikel-Nr. Article-No.						E.7748.1
d1	ER	l2	l1	d2 h6	Zähne flutes	€ Stück piece
6,00	0,5	13	57	6,0	6	
6,00	1,0	13	57	6,0	6	
8,00	0,5	19	63	8,0	6	
8,00	1,0	19	63	8,0	6	
10,00	0,5	22	72	10,0	6	
10,00	1,0	22	72	10,0	6	
12,00	0,5	26	83	12,0	6	
12,00	1,0	26	83	12,0	6	
12,00	1,5	26	83	12,0	6	
12,00	2,0	26	83	12,0	6	
12,00	2,5	26	83	12,0	6	
16,00	0,5	32	92	16,0	8	
16,00	1,0	32	92	16,0	8	
16,00	1,5	32	92	16,0	8	
16,00	2,0	32	92	16,0	8	
16,00	2,5	32	92	16,0	8	
16,00	3,0	32	92	16,0	8	
20,00	2,0	38	104	20,0	8	

VHM-Formenbau-Schaftfräser 50° mit Eckenradius XL

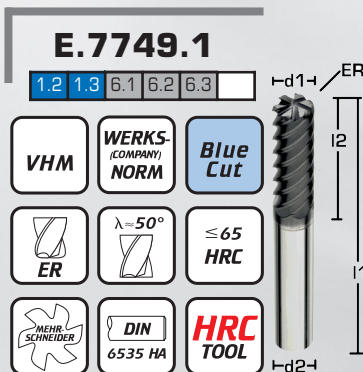

Solid carbide end mills 50° with corner radius for moulds XL

Frezy z węgla spiekanego wieloostrzowe bardzo długie 50° z promieniem na czole do form





Frese MD 50° per stampi con raggio d'angolo, serie extra lunga

Fresas de metal duro de 50° para moldes con radio lateral, serie extra larga

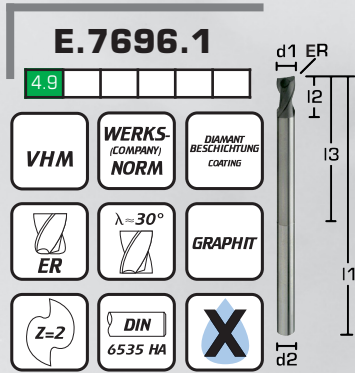
Artikel-Nr. Article-No.						E.7749.1
d1	ER	l2	l1	d2	Zähne flutes	€ Stück piece
6,00	0,5	18	62	6,0	6	
8,00	0,5	24	68	8,0	6	
8,00	1,0	24	68	8,0	6	
10,00	0,5	30	80	10,0	6	
10,00	1,5	30	80	10,0	6	
12,00	0,5	36	93	12,0	6	
12,00	1,0	36	93	12,0	6	
12,00	1,5	36	93	12,0	6	
12,00	2,0	36	93	12,0	6	
16,00	0,5	48	108	16,0	8	
16,00	1,0	48	108	16,0	8	
16,00	1,5	48	108	16,0	8	
16,00	2,0	48	108	16,0	8	
20,00	2,0	60	126	20,0	8	

VHM-Graphit-Mikroschaftfräser 30° mit Eckenradius



-  Solid carbide graphite micro end mills 30° with corner radius
-  Frezy miniaturowe z węglika spiekanego dwustrzowe 30° z promieniem na czole do grafitu
-  Microfresa MD 30° per grafite con raggio d'angolo
-  Microfresas de metal duro de 30° para grafito con radio lateral

Frästiefe bis 25xd
Milling depth up to 25xd

Lieferzeit: 2 Wochen
Delivery time: 2 weeks

Artikel-Nr. Article-No.							E. 7696.1
d1	ER	l2	l3	l1	d2 h5	€ Stück piece	
0,20	0,05	0,2	1,0	55	3,0		
0,30	0,05	0,3	1,0	55	3,0		
0,30	0,05	0,3	3,0	55	3,0		
0,40	0,05	0,4	2,0	55	3,0		
0,40	0,05	0,4	4,0	55	3,0		
0,40	0,05	0,4	8,0	55	3,0		
0,50	0,05	0,5	2,0	55	3,0		
0,50	0,05	0,5	5,0	55	3,0		
0,50	0,05	0,5	10,0	55	3,0		
0,60	0,06	0,8	3,0	55	3,0		
0,60	0,06	0,8	6,0	55	3,0		
0,60	0,06	0,8	9,0	55	3,0		
0,60	0,06	0,8	12,0	55	3,0		
0,80	0,08	1,0	4,0	55	3,0		
0,80	0,08	1,0	8,0	55	3,0		
0,80	0,08	1,0	12,0	55	3,0		
0,80	0,08	1,0	16,0	55	3,0		
1,00	0,10	1,0	5,0	55	3,0		
1,00	0,10	1,0	10,0	55	3,0		
1,00	0,10	1,0	15,0	55	3,0		
1,00	0,10	1,0	20,0	55	3,0		
1,00	0,10	1,0	25,0	55	3,0		
1,20	0,12	1,5	5,0	55	3,0		
1,20	0,12	1,5	10,0	55	3,0		
1,20	0,12	1,5	15,0	55	3,0		
1,50	0,15	2,0	5,0	55	3,0		
1,50	0,15	2,0	7,5	55	3,0		
1,50	0,15	2,0	10,0	55	3,0		
1,50	0,15	2,0	15,0	55	3,0		
1,50	0,15	2,0	20,0	55	3,0		
1,50	0,15	2,0	25,0	55	3,0		
1,80	0,18	2,0	10,0	55	3,0		
1,80	0,18	2,0	20,0	55	3,0		
2,00	0,20	2,0	10,0	65	3,0		
2,00	0,20	2,0	15,0	65	3,0		
2,00	0,20	2,0	20,0	65	3,0		
2,00	0,20	2,0	25,0	65	3,0		
2,00	0,50	2,0	10,0	65	3,0		
2,00	0,50	2,0	15,0	65	3,0		
2,00	0,50	2,0	20,0	65	3,0		
2,00	0,50	2,0	25,0	65	3,0		
3,00	0,30	3,0	15,0	65	4,0		
3,00	0,30	3,0	25,0	75	4,0		
3,00	0,50	3,0	10,0	65	4,0		
3,00	0,50	3,0	15,0	65	4,0		
3,00	0,50	3,0	20,0	65	4,0		
3,00	0,50	3,0	25,0	75	4,0		
3,00	0,50	3,0	30,0	75	4,0		
4,00	0,40	4,0	15,0	65	5,0		
4,00	0,40	4,0	25,0	75	5,0		
4,00	0,50	4,0	20,0	65	5,0		

- Gewindebohrer 1
- Bohren HSSE 2
- Bohren VHM 3
- Reiben HSSE 4
- Reiben VHM 5
- Frässtifte VHM 6
- Graphit 7
- WP-Werkzeuge 8
- Fräsen HSSE 9
- Sägen 10
- Lehren 11
- Nachschleifen 12
- Sonstiges 13

Fortsetzung nächste Seite to be continued

VHM-Graphit-Mikroschaftfräser 30° mit Eckenradius

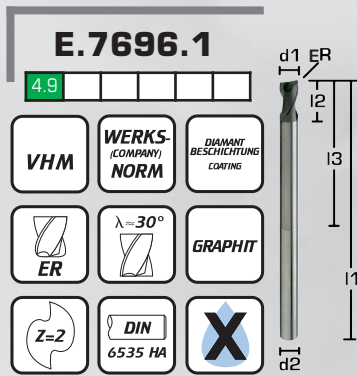

 Solid carbide graphite micro end mills 30° with corner radius

 Frezy miniaturowe z węgla spiekane go dwuostrzowe 30° z promieniem na czole do grafitu

 Microfresse MD 30° per grafite con raggio d'angolo

 Microfresas de metal duro de 30° para grafito con radio lateral

Frästiefe bis 25xd
Milling depth up to 25xd

Lieferzeit: 2 Wochen
Delivery time: 2 weeks

Artikel-Nr. Article-No.						E.7696.1
d1	ER	l2	l3	l1	d2 h5	€ Stück piece
4,00	0,50	4,0	40,0	75	5,0	
4,00	0,50	4,0	50,0	90	5,0	
5,00	0,50	5,0	30,0	75	6,0	
5,00	0,50	5,0	40,0	75	6,0	
5,00	0,50	5,0	50,0	90	6,0	
5,00	0,50	5,0	60,0	90	6,0	
6,00	0,50	6,0	30,0	75	6,0	
6,00	0,50	6,0	40,0	90	6,0	
6,00	0,50	6,0	30,0	90	6,0	
6,00	0,50	6,0	60,0	100	6,0	
6,00	1,00	6,0	30,0	75	6,0	
6,00	1,00	6,0	60,0	90	6,0	
8,00	0,50	8,0	30,0	80	8,0	
8,00	0,50	8,0	60,0	100	8,0	
8,00	1,00	8,0	30,0	80	8,0	
8,00	1,00	8,0	60,0	100	8,0	
10,00	0,50	10,0	30,0	80	10,0	
10,00	0,50	10,0	60,0	100	10,0	
10,00	1,00	10,0	30,0	80	10,0	
10,00	1,00	10,0	60,0	100	10,0	
12,00	0,50	12,0	30,0	80	12,0	
12,00	0,50	12,0	60,0	100	12,0	
12,00	1,00	12,0	30,0	80	12,0	
12,00	1,00	12,0	60,0	100	12,0	

VHM-Graphit-Mikroradiusfräser 30°

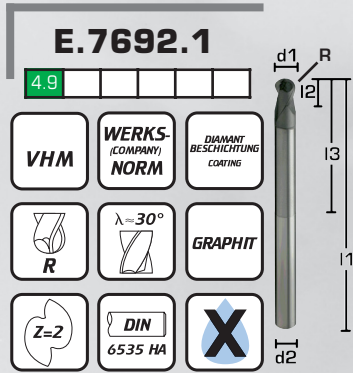

Solid carbide graphite micro ball nose end mills 30°

Frezy miniaturowe z węgla spiekanego dwustrzowe 30° z czołem kulistym do grafitu

Microfresa raggiate MD 30° per grafite

Microfresas de metal duro de 30° con radio para grafito

Frästiefe bis 25xd
Milling depth up to 25xd

Lieferzeit: 2 Wochen
Delivery time: 2 weeks

Artikel-Nr. Article-No.						E.7692.1
d1	R	l2	l3	l1	d2 h5	€ Stück piece
0,20	0,10	0,2	1	55	3,0	
0,30	0,15	0,3	1	55	3,0	
0,30	0,15	0,3	3	55	3,0	
0,30	0,15	0,3	5	55	3,0	
0,30	0,15	0,3	8	55	3,0	
0,40	0,20	0,4	4	55	3,0	
0,40	0,20	0,4	6	55	3,0	
0,40	0,20	0,4	8	55	3,0	
0,50	0,25	0,5	5	55	3,0	
0,50	0,25	0,5	10	55	3,0	
0,60	0,30	0,8	6	55	3,0	
0,60	0,30	0,8	9	55	3,0	
0,60	0,30	0,8	12	55	3,0	
0,70	0,35	0,9	7	55	3,0	
0,70	0,35	0,9	14	55	3,0	
0,80	0,40	1,0	8	55	3,0	
0,80	0,40	1,0	12	55	3,0	
0,80	0,40	1,0	16	55	3,0	
1,00	0,50	1,0	5	55	3,0	
1,00	0,50	1,0	10	55	3,0	
1,00	0,50	1,0	15	55	3,0	
1,00	0,50	1,0	20	55	3,0	
1,00	0,50	1,0	25	55	3,0	
1,00	0,50	1,0	30	55	3,0	
1,20	0,60	1,5	5	55	3,0	
1,20	0,60	1,5	10	55	3,0	
1,20	0,60	1,5	15	55	3,0	
1,50	0,75	2,0	5	55	3,0	
1,50	0,75	2,0	10	55	3,0	
1,50	0,75	2,0	15	55	3,0	
1,50	0,75	2,0	20	55	3,0	
1,50	0,75	2,0	25	55	3,0	
1,80	0,90	2,0	10	55	3,0	
1,80	0,90	2,0	20	55	3,0	
2,00	1,00	2,0	10	55	3,0	
2,00	1,00	2,0	15	55	3,0	
2,00	1,00	2,0	20	55	3,0	
2,00	1,00	2,0	25	65	3,0	
2,00	1,00	2,0	30	65	3,0	
3,00	1,50	3,0	10	65	4,0	
3,00	1,50	3,0	15	65	4,0	
3,00	1,50	3,0	20	65	4,0	
3,00	1,50	3,0	25	75	4,0	
3,00	1,50	3,0	30	75	4,0	
4,00	2,00	4,0	20	65	5,0	
4,00	2,00	4,0	30	75	5,0	
4,00	2,00	4,0	40	90	5,0	
5,00	2,50	5,0	20	65	6,0	
5,00	2,50	5,0	30	75	6,0	
5,00	2,50	5,0	40	90	6,0	
5,00	2,50	5,0	50	90	6,0	

- 1 Gewindebohrer
- 2 Bohren HSSE
- 3 Bohren VHM
- 4 Reiben HSSE
- 5 Reiben VHM
- 6 Frässtifte VHM
- 7 Graphit
- 8 WP-Werkzeuge
- 9 Fräsen HSSE
- 10 Sägen
- 11 Lehren
- 12 Nachschleifen
- 13 Sonstiges

Fortsetzung nächste Seite to be continued

VHM-Graphit-Mikroradiusfräser 30°

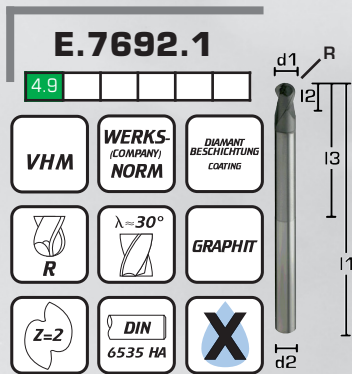

Solid carbide graphite micro ball nose end mills 30°

Frezy miniaturowe z węgla spiekanego dwuostrzowe 30° z czolem kulistym do grafitu

Microfresse raggriate MD 30° per grafite

Microfresas de metal duro de 30° con radio para grafito

Frästiefe bis 25xd
Milling depth up to 25xd

Lieferzeit: 2 Wochen
Delivery time: 2 weeks

Artikel-Nr. Article-No.						E.7692.1
d1	R	l2	l3	l1	d2 h5	€ Stück piece
6,00	3,00	6,0	30	75	6,0	
6,00	3,00	6,0	40	90	6,0	
6,00	3,00	6,0	50	90	6,0	
6,00	3,00	6,0	60	100	6,0	
8,00	4,00	8,0	30	80	8,0	
8,00	4,00	8,0	60	100	8,0	
10,00	5,00	10,0	30	80	10,0	
10,00	5,00	10,0	60	100	10,0	
12,00	6,00	12,0	30	83	12,0	
12,00	6,00	12,0	60	100	12,0	

VHM-Graphit-Schaftfräser 30° XL mit Eckenradius

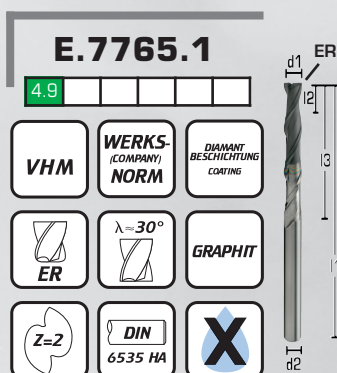

Solid carbide graphite end mills 30° XL with corner radius

Frezy z węgla spiekanego dwuostrzowe bardzo długie 30° do grafitu z promieniem na czole

Microfresse MD 30° per grafite, serie extra lunga con raggio d'angolo

Fresas de metal duro de 30° para grafito, serie extra larga con radio lateral

Artikel-Nr. Article-No.						E.7765.1
d1 h10	ER	l2	l3	l1	d2 h6	€ Stück piece
2,00	0,5	10	20	100	3,0	
3,00	0,5	12	24	100	3,0	
4,00	0,5	15	30	100	4,0	
5,00	0,5	15	30	100	5,0	
6,00	0,5	25	50	100	6,0	
6,00	1,0	30	60	150	6,0	
8,00	1,0	25	50	100	8,0	
8,00	1,0	30	60	150	8,0	
10,00	1,0	30	60	150	10,0	
12,00	1,0	40	80	150	12,0	
16,00	1,5	40	80	150	16,0	

VHM-Graphit-Radiuskopierfräser 30°

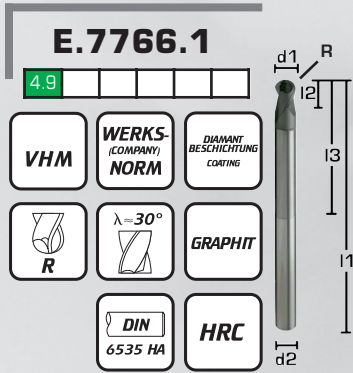

Solid carbide graphite ball nose copy cutters 30°

Frezy z węglika spiekane go wielostrzowe kopiowe 30° z czodem kulistym do grafitu

Frese raggiate a copiare MD 30° per grafite

Fresas de metal duro de 30° con radio para grafito, para copiado

Artikel-Nr. Article-No.						E.7766.1 € Stück piece
d1 h10	R	l2	l3	l1	d2	
1,00	0,50	2,0	4	57	6,0	
1,50	0,75	2,5	5	57	6,0	
2,00	1,00	3,0	6	57	6,0	
2,50	1,25	3,5	7	57	6,0	
3,00	1,50	4,0	8	80	6,0	
4,00	2,00	5,0	10	57	6,0	
4,00	2,00	6,0	12	80	6,0	
5,00	2,50	7,0	14	57	6,0	
5,00	2,50	7,0	14	80	6,0	
6,00	3,00	9,0	18	100	10,0	
6,00	3,00	10,0	20	120	10,0	
8,00	4,00	12,0	24	120	10,0	
8,00	4,00	12,0	24	150	12,0	
10,00	5,00	14,0	28	150	12,0	
10,00	5,00	14,0	28	150	14,0	
12,00	6,00	16,0	32	150	14,0	
12,00	6,00	16,0	32	150	16,0	
16,00	8,00	20,0	40	150	20,0	

- Gewindebohrer 1
- Bohren HSSE 2
- Bohren VHM 3
- Reiben HSSE 4
- Reiben VHM 5
- Frässtifte VHM 6
- Graphit 7
- WP-Werkzeuge 8
- Fräsen HSSE 9
- Sägen 10
- Lehren 11
- Nachschleifen 12
- Sonstiges 13

VHM-Graphit-Radiusschaftfräser engverzahnt mit Spanteiler

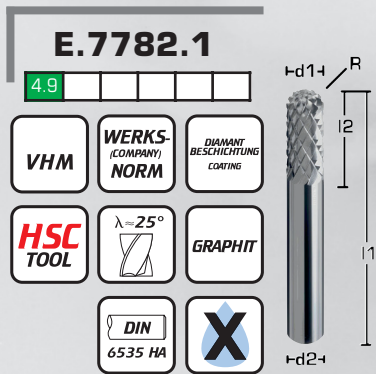

Solid carbide graphite ball nose end mills fine cut with chip breaker

Frezy z węgla spiekanego wieloostrowe z czołem kulistym i lamaczem wióra do grafitu

Frese raggiate MD 30° per grafite, dentature fine con rompitruciolo

Fresas de metal duro con radio para grafito, dentado apretado con rompevirutas

Artikel-Nr. Article-No.					E.7782.1 € Stück piece
d1	R	l2	l1	d2 h6	
3,00	1,50	10	40	3,0	
3,50	1,75	10	40	3,5	
4,00	2,00	11	40	4,0	
4,50	2,25	11	50	4,5	
5,00	2,50	13	50	5,0	
6,00	3,00	16	50	6,0	
7,00	3,50	16	60	7,0	
8,00	4,00	19	63	8,0	
9,00	4,50	19	63	9,0	
10,00	5,00	22	72	10,0	
11,00	5,50	22	72	11,0	
12,00	6,00	26	83	12,0	
14,00	7,00	26	83	14,0	
16,00	8,00	32	92	16,0	
18,00	9,00	32	92	18,0	
20,00	10,00	38	104	20,0	

VHM-Graphit-Schaftfräser 30°

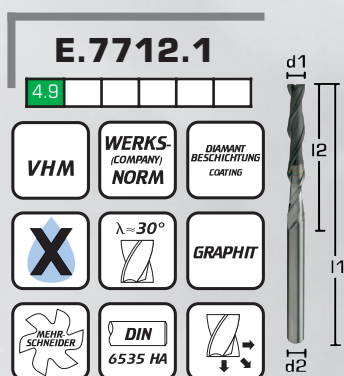

Solid carbide graphite end mills 30°

Frezy z węgla spiekanego wieloostrowe 30° do grafitu

Frese in MD 30° per grafite

Fresas de metal duro de 30° para grafito

Artikel-Nr. Article-No.					E.7712.1 € Stück piece
d1	l2	l1	d2 h6	Zähne flutes	
1,00	3	38	1,0	2	
1,50	4	38	1,5	2	
2,00	7	40	2,0	2	
3,00	10	40	3,0	3	
4,00	11	40	4,0	3	
5,00	13	50	5,0	3	
6,00	16	50	6,0	3	
8,00	20	63	8,0	3	
10,00	22	72	10,0	4	
12,00	26	83	12,0	4	

VHM-Graphit-Torusfräser 30°

E.7767.1

4.9

VHM WERKS (COMPANY) NORM DIAMANT BESCHICHTUNG COATING

ER $\lambda=30^\circ$ GRAPHIT

HSC TOOL DIN 6535 HA HRC

Solid carbide graphite torus end mills 30°

Frezy z węgla spiekanego wieloostrowe 30° torusowe do grafitu

Frese in MD toriche 30° per grafite

Fresas tóricas de metal duro de 30° para grafito

Artikel-Nr. Article-No.					E.7767.1 € Stück piece
d1 h10	ER	l2	l1	d2 h6	
2,00	0,5	6	50	3,0	
3,00	0,5	8	60	3,0	
4,00	0,5	10	60	4,0	
5,00	0,5	12	60	5,0	
6,00	0,5	20	75	6,0	
8,00	1,0	20	75	8,0	
10,00	1,0	25	100	10,0	
12,00	1,0	25	100	12,0	
16,00	1,5	25	100	16,0	

VHM-Graphit-Nutenfräser mit spezieller Kreuzverzahnung

E.7778.1

4.9

VHM WERKS (COMPANY) NORM DIAMANT BESCHICHTUNG COATING

$\lambda=30^\circ$ GRAPHIT

DIN 6535 HA X

E.7779.1

4.9

VHM WERKS (COMPANY) NORM DIAMANT BESCHICHTUNG COATING

$\lambda=25^\circ$ GRAPHIT

DIN 6535 HA X

Solid carbide graphite slot milling cutters with special cross cut

Frezy z węgla spiekanego wieloostrowe do grafitu ze specjalnym ostrzem do rowkowania

Frese MD speciali per grafite con denti incrociati

Fresas de metal duro para ranurar grafito con diente cruzado especial

Artikel-Nr. Article-No.				E.7778.1 € Stück piece	E.7779.1 € Stück piece
d1	l2	l1	d2 h6		
2,00	7	40	2,0		
2,00	7	50	6,0		
3,00	10	40	3,0		
3,00	12	50	6,0		
4,00	15	40	4,0		
4,00	20	50	6,0		
5,00	16	50	5,0		
5,00	25	75	6,0		
6,00	18	50	6,0		
6,00	35	75	6,0		
8,00	25	63	8,0		
8,00	40	100	8,0		
10,00	30	72	10,0		
12,00	32	83	12,0		
16,00	36	92	16,0		
20,00	40	104	20,0		

- 1 Gewindebohrer
- 2 Bohren HSSE
- 3 Bohren VHM
- 4 Reiben HSSE
- 5 Reiben VHM
- 6 Frässtifte VHM
- 7 Graphit
- 8 WP-Werkzeuge
- 9 Fräsen HSSE
- 10 Sägen
- 11 Lehren
- 12 Nachschleifen
- 13 Sonstiges

VHM-Graphit-Bohrfräser

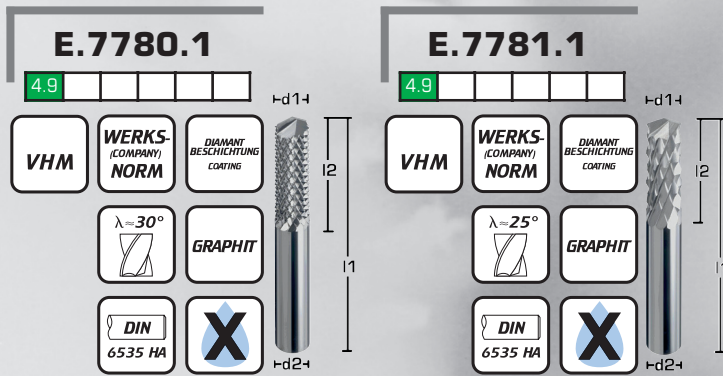

Solid carbide graphite drill milling cutter

Frezy z węgla spiekanego wieloostrowe do grafitu

Puntafrese in MD per grafite

Fresas-brocas de metal duro para grafito

Artikel-Nr. Article-No.				E.7780.1 € Stück piece	E.7781.1 € Stück piece
d1	l2	l1	d2 h6		
2,00	7	40	2,0		
2,00	7	50	6,0		
3,00	10	40	3,0		
3,00	12	50	6,0		
4,00	15	40	4,0		
4,00	20	50	6,0		
5,00	16	50	5,0		
5,00	25	75	6,0		
6,00	18	50	6,0		
6,00	35	75	6,0		
8,00	25	63	8,0		
8,00	40	100	8,0		
10,00	30	72	10,0		
12,00	32	83	12,0		
16,00	36	92	16,0		
20,00	40	104	20,0		

VHM-Graphit-Schaftfräser 30°

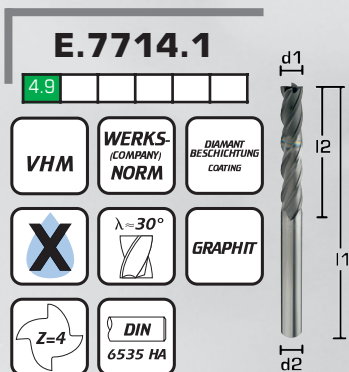

Solid carbide graphite end mills 30°

Frezy z węgla spiekanego czteroostrowe 30° do grafitu

Frese in MD per grafite

Fresas de metal duro de 30° para grafito

Artikel-Nr. Article-No.				E.7714.1 € Stück piece
d1 h7	l2	l1	d2 h6	
6,00	45	80	6,0	
8,00	50	100	8,0	
10,00	50	100	10,0	
12,00	70	150	12,0	
14,00	75	150	14,0	
16,00	75	150	16,0	

VHM-Vollstäbe K40, geschliffen h6

E.7783.0

VHM



 Solid carbide rods K40, ground to tolerance h6

 Półwyroby okrągłe K40 z węglika spiekanego w tolerancji h6

 Barrette MD K40, rettificate h6

 Barras de metal duro integral K40, rectificadas h6

Artikel-Nr. Article-No.		E.7783.0		Artikel-Nr. Article-No.		E.7783.0	
d1 h6	l1	€	Stück piece	d1 h6	l1	€	Stück piece
3,00	330			13,00	330		
3,50	330			14,00	330		
4,00	330			15,00	330		
4,50	330			16,00	330		
5,00	330			17,00	330		
5,50	330			18,00	330		
6,00	330			19,00	330		
6,50	330			20,00	330		
7,00	330			22,00	330		
7,50	330			25,00	330		
8,00	330			28,00	330		
8,50	330			30,00	330		
9,00	330			32,00	330		
9,50	330			35,00	330		
10,00	330			38,00	330		
12,00	330			40,00	330		

VHM-Fixlängen K40, geschliffen h6

E.7784.0

VHM



 Solid carbide rods K40, ground to tolerance h6

 Półwyroby okrągłe K40 z węglika spiekanego w tolerancji h6

 Barrette MD tagliate a misura K40, rettificate h6

 Barras de metal duro integral K40, rectificadas h6, longitudes fijas

Artikel-Nr. Article-No.		E.7784.0	
d1 h6	l1	€	Stück piece
3,00	100		
4,00	100		
5,00	100		
6,00	100		
7,00	100		
8,00	100		
9,00	100		
10,00	100		
11,00	100		
12,00	100		
13,00	100		

- 1 Gewindebohrer
- 2 Bohren HSSE
- 3 Bohren VHM
- 4 Reiben HSSE
- 5 Reiben VHM
- 6 Frässtifte VHM
- 7 Rundstäbe
- 8 WP-Werkzeuge
- 9 Fräsen HSSE
- 10 Sägen
- 11 Lehren
- 12 Nachschleifen
- 13 Sonstiges

VHM-Fräser-Rohlinge K40, geschliffen h6, mit einseitiger Fase

E.7752.0



Milling cutter blanks, ground to tolerance h6, chamfered one end

Półwyroby okrągłe z węgla spiekane-go w tolerancji h6 z jednym skośnym

Barrette MD per frese K40, rettificate h6, con smusso unilaterale

Fresas semielaboradas en metal duro integral K40, rectificadas h6, con chafián unilateral

Artikel-Nr. Article-No.		E.7752.0
d1 h6	l1	€ Stück piece
2,00	32,5	
3,00	39,5	
4,00	40,5	
4,00	51,0	
4,50	51,2	
5,00	51,2	
5,50	58,2	
6,00	51,2	
6,00	55,0	
6,00	58,2	
6,50	62,0	
7,00	62,0	
7,50	65,0	
8,00	59,0	
8,00	64,2	
8,50	69,0	
9,00	69,0	
9,50	74,0	
10,00	67,2	
10,00	73,2	
11,00	85,0	
12,00	74,2	
12,00	84,2	
13,00	85,0	
14,00	76,2	
14,00	84,2	
15,00	94,0	
16,00	83,2	
16,00	93,2	
18,00	85,0	
18,00	93,0	
20,00	93,2	
20,00	105,0	
25,00	123,0	
25,00	151,2	